

GANEX

Newsletter No. 17

May 2014

III-N Technology

Coordinated by CRHEA-CNRS research laboratory, this monthly newsletter is produced by Knowmade with collaboration from the managers of GANEX groups. The newsletter presents a selection of newest scientific publications, patent applications and press releases related to III-Nitride semiconductor materials (Ga, AlN, InN and alloys)

All issues on www.ganex.fr in *Veille* section.

Free subscription <http://www.knowmade.com/ganex.html>

GANEX

Cluster of Excellence (Labex, 2012-2019)

GANEX is a cluster gathering French research teams involved in GaN technology. The objective of GANEX is to strengthen the position of French academic players in terms of knowledge and visibility, and strengthen the French industrials in terms of know-how and market share.

www.ganex.fr



KnowMade is specialized in analysis of patents and scientific information. We provide patent search, IP landscape, patent valuation, IP due diligence, scientific literature landscape, identification of technologies available for transfer/licensing/sale, alerts and updates. Our service offer consists of custom studies, analysis reports, on-demand tracking and strategy consulting. Knowmade combines information search services, scientific expertise, powerful analytics and visualization tools, and proprietary methodologies for analyzing patents and scientific information. With a solid focus on Microelectronics, Nanotechnology and Biotechnology, KnowMade supports research laboratories, industrial companies and investors in their business development.

www.knowmade.com

METHODOLOGY

Sources

10+ scientific journal editors

*Elsevier, IOP, IEEE, Wiley, Springer,
APS, AIP, AVS, ECS, Nature, Science ...*

10+ specialist magazines

*Semiconductor Today, ElectroIQ, i-micronews,
Compound Semiconductor, Solid State Technology ...*

5+ open access database: *FreeFulPDF, DOAJ ...*

Patent database: *Questel-Orbit*

Each month

250+ new scientific publications

120+ new patent applications

20+ new press releases

**Selection by
III-N French
experts**

GANEX

monthly newsletter

TABLE OF CONTENTS

(clickable links to chapters)

SCIENTIFIC PUBLICATION	4
GROUP 1 - LEDs and Lighting	4
GROUP 2 - Laser and Coherent sources.....	7
GROUP 3 - Power Electronics.....	9
GROUP 4 - Advanced Electronics and RF	13
GROUP 5 - Sensors and MEMS.....	16
GROUP 6 - Photovoltaics and Energy harvesting.....	20
GROUP 7 - Materials, Technology and Fundamental.....	22
PRESS RELEASE	32
PRO NETWORK	46
PATENT APPLICATION	48

SCIENTIFIC PUBLICATION

Selection of new scientific articles

GROUP 1 - LEDs and Lighting

Group leader: Benjamin Damilano (CRHEA-CNRS)

Information selected by Benjamin Damilano (CRHEA-CNRS)

Time Evolution Degradation Physics in High Power White LEDs under high temperature-humidity conditions

Tan, C. ; C.M. ; Singh, P.

School of EEE, Nanyang Technological University, Singapore.

Device and Materials Reliability, IEEE Transactions on
<http://dx.doi.org/10.1109/TDMR.2014.2318725>

High temperature-humidity test is commonly employed to evaluate the humidity reliability of electronic devices. For integrated circuit, the degradation mechanism under high temperature-humidity test is metal corrosion, and Peck's model is used for extrapolating the test results at accelerated test conditions to normal operating condition. Such extrapolation is possible as the underlying degradation physics is invariant from the accelerated test conditions to normal operating condition for integrated circuits. However, this is not true for high power LEDs as found in this work. The degradation in the LEDs undergoes time evolution at either 95% or 85% relative humidity (RH) and 85°C. We also found that the degradation physics are completely different among the various RH levels from 95% to 70%. The degradation process begins from bondpad contamination and Kirkendall voids formation, galvanic dissolution, phosphor dissolution to encapsulant and die attach delamination. Such time evolution degradation physics renders the inapplicability of the Peck model and presents a challenge in extrapolation of test results to normal operating condition for lifetime prediction.

On the Carrier Injection Efficiency and Thermal Property of InGaN/GaN Axial Nanowire Light Emitting Diodes

Zhang, S. ; Connie, A.T. ; Laleyan, D.A. ; Pham Trung Nguyen, H. ; Wang, Q. ; Song, J. ; Shih, I. ; Mi, Z.

Shaofei Zhang is with Department of Electrical and Computer Engineering, McGill University, Montreal, QC H3A 0E9 Canada

Quantum Electronics, IEEE Journal of
<http://dx.doi.org/10.1109/JQE.2014.2317732>

We have investigated the impact of surface recombination on the effective carrier injection efficiency and the Joule heating of axial InGaN/GaN nanowire LEDs. The results reveal that the carrier injection efficiency of such devices is extremely low (<10%), due to the severe carrier loss through nonradiative surface recombination. It is further observed that the thermal resistance of typical nanowire LEDs is comparable to, or lower than that of their planar counterparts, in spite of the reduced thermal conductivity of nanowires. The poor carrier injection efficiency, however, leads to significantly elevated junction temperatures for nanowire LEDs. We have further demonstrated, both theoretically and experimentally, that the carrier injection efficiency can be significantly improved in p-doped nanowires, due to the downward surface band bending, and in InGaN/GaN/AlGaIn dot-in-a-wire core-shell nanoscale heterostructures, due to the superior carrier confinement offered by the large bandgap AlGaIn shell. This study offers important insight for the design and epitaxial growth of high performance nanowire LEDs.

Polarity dependence of the electrical characteristics of Ag reflectors for high-power GaN-based light emitting diodes

Jae-Seong Park¹, Jaecheon Han², Jun-Seok Ha³ and Tae-Yeon Seong^{1,a)}

¹ Department of Materials Science and Engineering, Korea University, Seoul 136-713, South Korea

² Department of LED Business, Chip Development Group, LG Innotek, Paju 413-901, South Korea

³ School of Applied Chemical Engineering, Chonnam National University, Gwangju 500-757, South Korea

Applied Physics Letters
Vol. 104, 172104 (2014);
<http://dx.doi.org/10.1063/1.4874631>

We report on the polarity dependence of the electrical properties of Ag reflectors for high-power GaN-based light-emitting diodes. The (0001) c-plane samples become ohmic after annealing in air. However, the (11–22) semi-polar samples are non-ohmic after annealing, although the 300 °C-annealed sample shows the lowest contact resistivity. The X-ray photoemission spectroscopy (XPS) results show that the Ga 2p core level for the c-plane samples experiences larger shift toward the valence band than that for the semi-polar samples. The XPS depth profile results show that unlike the c-plane samples, the semi-polar samples contain some amounts of oxygen at the Ag/GaN interface regions. The outdiffusion of Ga atoms is far more significant in the c-plane samples than in the semi-polar samples, whereas the outdiffusion of N atoms is relatively less significant in the c-plane samples. On the basis of the electrical and XPS results, the polarity dependence of the electrical properties is described and discussed

Integrated photonic platform based on InGaN/GaN nanowire emitters and detectors

Maria Tchernycheva , Agnès Messanvi , Andres de Luna Bugallo , Gwenole Jacopin , Pierre Lavenus , Lorenzo Rigutti , Hezhi Zhang , Yacine Halioua , François H. Julien , Joel Eymery , and Christophe Durand

Nano Letters
<http://dx.doi.org/10.1021/nl501124s>

We report on the fabrication of a photonic platform consisting of single wire light emitting diodes (LED) and photodetectors optically coupled by waveguides. MOVPE-grown InGaN/GaN p-n junction core-shell nanowires have been used for device fabrication. To achieve a good spectral matching between the emission wavelength and the detection range, different active regions containing either five narrow InGaN/GaN quantum wells or one wide InGaN segment were employed for the LED and detector, respectively. The communication wavelength is 400 nm. The devices are realized by means of electron beam

lithography on Si/SiO₂ templates and connected by 100 μm long non-rectilinear SiN waveguides. The photodetector current trace shows signal variation correlated with the LED on/off switching with a fast transition time below 0.5 sec.

Green-Light Nanocolumn Light Emitting Diodes with Triangular-Lattice Uniform Arrays of InGaN-Based Nanocolumns

Kishino, K. ; Yamano, K.
Department of Engineering and Applied Sciences,
Sophia University, 7-1 Kioi-cho, Chiyoda-ku, Tokyo 102-8554, Japan

Quantum Electronics, IEEE Journal of
<http://dx.doi.org/10.1109/JQE.2014.2325013>

Green-light nanocolumn LEDs consisting of triangular-lattice uniform arrays of InGaN-based nanocolumns with lattice constants of 245-350 nm were fabricated with TiO₂ mask selective-area growth by rf-plasma-assisted molecular beam epitaxy. The built-in core/shell structure of InGaN/GaN multiple quantum wells was self-assembled, confining carriers in the core of the nanocolumns. The characteristics of the nanocolumn LEDs were evaluated at room temperature under DC current injection in the range from 4.5 to 450 A/cm². The emission wavelengths were 515 to 550 nm, and small current-induced spectral blueshifts of 2-11 nm were observed. The linewidth narrowing at a low current density was very small for the nanocolumn LEDs, in which nanocolumns with the same size were homogeneously arranged. The sidewalls of the nanocolumns were passivated by the deposition of Al₂O₃, contributing to the elimination of current leakage paths. The external quantum efficiency was improved with the passivation. Radiation beam angular profiles of the nanocolumn LEDs were evaluated and directional beam radiation was observed at specific wavelengths, which was attributed to the photonic band edge of the periodic nanocolumn arrangement.

Vertical-Injection GaN-Based Light-Emitting Diodes Fabricated With Schottky-Contact Current Blocking Layer

Oh, M. ; ; Kim, H.

School of Semiconductor and Chemical Engineering,
Semiconductor Physics Research Center, Chonbuk
National University, Jeonju 561-756, Korea.

Electron Devices, IEEE Transactions on

<http://dx.doi.org/10.1109/TED.2014.2321160>

Vertical-injection GaN-based light-emitting diodes (LEDs) fabricated with a Schottky-contact current blocking layer (ScCBL) are reported. The Ar plasma treatment to the heavily Mg-doped p-GaN led to excellent rectifying Schottky behavior, which was found to occur as a result of the suppressed hopping conduction at the contact/p-GaN interface. This could be due to the preferential removal of the Mg dopants by the Ar plasma treatment, as verified by secondary ion mass spectroscopy. Compared with the reference LEDs fabricated with SiO₂ CBL, the LEDs fabricated with ScCBL showed an identifying current-voltage curve, while the output power increased 5%, indicating that the ScCBL fabricated with the Ar plasma treatment could be used practically to improve process yields and lower the cost of vertical LEDs.

Red-Emitting ($\lambda=610$ nm) In_{0.51}Ga_{0.49}N/GaN Disk-in- Nanowire Light Emitting Diodes on Silicon

Jahangir, S. ; Schimpke, T. ; Strassburg, M. ; Grossklaus, K.A. ; Millunchick, J.M. ; Bhattacharya, P.

Center for Photonics and Multiscale Nanomaterials,
Department of Electrical Engineering and Computer
Science, University of Michigan, Ann Arbor, MI 48109-
2122, USA

Quantum Electronics, IEEE Journal of

<http://dx.doi.org/10.1109/JQE.2014.2323952>

We have investigated the properties of In_{0.51}Ga_{0.49}N/GaN disk-in-nanowire light emitting diodes epitaxially grown on silicon substrates by plasma assisted molecular beam epitaxy. The radiative efficiency of the nanowire ensemble, obtained from the temperature dependent photoluminescence measurements,

under optimized growth conditions is 43%, which increases to 55% after parylene passivation. From high resolution transmission electron microscopy it is evident that there is significant coalescence between nanowires when the areal density approaches 10¹¹cm⁻². We have identified and characterized deep level electron and hole traps in the GaN nanowires and it is found that the trap densities increase with nanowire density, or with the degree of coalescence. It is therefore believed that the deep levels originate from dislocations and stacking faults arising from nanowire coalescence. The best output characteristics are measured in a light emitting diode having a nanowire density of 2x10¹⁰cm⁻², which exhibits a maximum internal quantum efficiency of ~55% at an injection level of 10A/cm². It is seen that the maximum efficiency would increase to 60% in the absence of deep level traps.

GROUP 2 - Laser and Coherent sources

Group leader: Bruno Gayral (CEA)

Information selected by Knowmade

Efficiency droop of GaN lasers and LEDs

Hader, J. ; ; Moloney, J.V. ; Koch, S.W.

Nonlinear Control Strategies Inc., 3542 N. Geronimo Ave., Tucson, Arizona, 85705, USA

Lasers and Electro-Optics Europe (CLEO EUROPE/IQEC), 2013 Conference on and International Quantum

Electronics Conference

<http://dx.doi.org/10.1109/CLEOE-IQEC.2013.6800733>

The density/current dependence of the internal efficiency (IQE) in GaN-based light emitting devices (LED) is commonly modelled using a cubic polynomial called the ABC law. Here, a linear density (N) dependence, AN, represents defect recombinations, a quadratic term, BN², is used for radiative losses and an Auger-like cubic term, CN³, is used to model the droop-causing losses. The model has been shown to be able to reproduce experimentally measured data quite successfully. However, when treating all three parameters, A, B, and C, as freely adjustable parameters fits of a single IQE curve usually leave a rather high degree of uncertainty. E.g., virtually identical results can be obtained varying the Auger coefficient by more than one order of magnitude if at the same time A and B are adjusted accordingly. This uncertainty not only obscures the accurate values for the strengths of the underlying mechanisms, but also prevents the model to be able to determine other dependencies like that on temperature which could yield more insight into which physical processes may be responsible for the droop.

Analysis of gain properties in silver-clad nanowire lasers

Sattar, Z.A. ; ; Shore, K.A.

Bangor University, School of Electronic Engineering, Bangor, LL57 1UT, Wales U.K.

Lasers and Electro-Optics Europe (CLEO EUROPE/IQEC), 2013 Conference on and International Quantum

Electronics Conference

<http://dx.doi.org/10.1109/CLEOE-IQEC.2013.6800771>

Miniaturization has been the ever-present motif of semiconductor laser design. Recently attention has been given to sub-wavelength semiconductor nano-lasers. Of particular interest is the so-called nanowire laser which offers significant potential as a fundamental building block for nanoscale electronic and photonic devices [1]. A specific class of such devices which has attracted recent interest is GaN nanowire lasers which aim to exploit the favourable properties of the semiconductor for short-wavelength optoelectronic devices [2,3].

Nanograting imprinted with femtosecond-laser-induced plasmonic near-field

Miyazaki, Kenzo ; ; Miyaji, Godai

Institute of Advanced Energy, Kyoto University, Gokasho, Uji, Kyoto, 611-0011, Japan

Lasers and Electro-Optics Europe (CLEO EUROPE/IQEC), 2013 Conference on and International Quantum

Electronics Conference

<http://dx.doi.org/10.1109/CLEOE-IQEC.2013.6801545>

As a promising approach to laser nanoprocessing, much interest has been focused on the self-organized, periodic surface nano structures that are often observed in the femtosecond (fs) laser ablation experiment [1], while the ultrafast interaction poses a significant challenge to controlling the nanostructuring process and fabricating well-defined nano structures. Here we demonstrate that surface plasmon polaritons (SPPs) [3] excited with fs laser pulses can generate periodically enhanced local fields to imprint a homogeneous nanograting on gallium nitride (GaN) surface in air.

Mirrorless optical parametric oscillator in a stitched GaN waveguide

Montes, Carlos ; ; Aschieri, Pierre ; de Micheli, Marc

LPMC-CNRS, Université de Nice-Sophia Antipolis, Parc Valrose, F-06108 Nice, France

Lasers and Electro-Optics Europe (CLEO EUROPE/IQEC), 2013 Conference on and International Quantum

Asymmetric GaN planar waveguides grown on (0001) sapphire by molecular beam epitaxy are promising submicro-metric periodically poled (PP) structures required for quasi-phase-matching the counterpropagating three-wave parametric interactions [1, 2]. However, the realization of cm long waveguides presenting a submicronic periodicity is not possible without moving the sample under the writing beam. This displacement introduces stitching errors. The device must then be formed by a chain of multiple PPGaN elements, each of about 100 mm long, jointed by uniformly polarized domains of mm length representing stitching errors. A mirrorless optical parametric oscillator (MOPO) was experimentally realized in a bold KTiOPO₄ crystal by using the periodically-poled PPKTP with sub-mm periodicity [3]. Now we investigate a MOPO for a fragmented PPGaN waveguide. One of the remarkable properties of the PPKTP bulk MOPO with a chirped pump was the strong asymmetry in the spectral bandwidth: the bandwidth of the forward signal was comparable to that of the pump, whereas the bandwidth of the backward idler was typically one to two orders of magnitude narrower [4, 5]. Quite surprisingly here, the structure presenting stitching errors is almost as efficient as a perfect one because the generated coherent phase of the backscattered wave locks the phases of the forward propagating waves in such a way that they are almost insensitive to the junctions where quasi-phase-matching is not preserved. Regardless if the phase modulation in the pump is deterministic or stochastic, the backward parametric wave always has a bandwidth that is narrow compared to that of the forward wave.

Fabrication and characteristics of a GaN-based microcavity laser with shallow etched mesa

Ying-Yu Lai, Yu-Hsun Chou, Yu-Sheng Wu, Yu-Pin Lan, Tien-Chang Lu and Shing-Chung Wang
Department of Photonics, National Chiao Tung University, Hsinchu 300, Taiwan

Applied Physics Express

Vol. 7; 062101

<http://dx.doi.org/10.7567/APEX.7.062101>

In this work, we have developed a simple GaN-based microcavity (MC) with an intracavity shallow etched mesa. The textured GaN-based MC incorporated two high-reflectivity dielectric Bragg mirrors and an InGaN/GaN multiple quantum well with a shallow etched mesa as an optical confined structure. Lasing and transverse optical confinement characteristics have been verified by measuring devices with different mesa diameters. A quality factor (Q) of 2600 and a threshold energy of 30 nJ have been observed in a 10- μ m-diameter device. Such a cavity structure could be implanted into electrically pumped GaN vertical-cavity surface-emitting lasers for supporting efficient transverse confinement.

Light confinement in hexagonal GaN nanodisk with whispering gallery mode

Tetsuya Kouno¹, Masaru Sakai², Katsumi Kishino³ and Kazuhiko Hara¹

¹ Department of Electronics and Material Science, Shizuoka University, Hamamatsu 432-8011, Japan

² Interdisciplinary Graduate School of Medicine and Engineering, University of Yamanashi, Kofu 400-8511, Japan

³ Department of Engineering and Applied Sciences, Sophia University, Chiyoda, Tokyo 102-8554, Japan

Japanese Journal of Applied Physics

Vol. 53; 068005

<http://dx.doi.org/10.7567/JJAP.53.068005>

We demonstrated light confinement in hexagonal GaN nanodisks. The nanodisks were fabricated by crystal growth via radio-frequency plasma-assisted molecular beam epitaxy, and the side length of the nanodisks was approximately 300 nm. Sharp peaks appeared at a wavelength of approximately 370 nm in the room-temperature photoluminescence spectrum of the nanodisks, indicating that the nanodisks acted as an optical nanoresonator. In addition, the results obtained by a finite-difference time domain method suggest that the resonant mode acting preferentially in such nanodisks is the whispering gallery mode. These results indicate that the GaN-based simple nanostructures can be used for nanolasers.

GROUP 3 - Power Electronics

Group leader: Erwan Morvan (CEA-Leti)

Information selected by Erwan Morvan (CEA-Leti)

GaN for automotive applications

Nishikawa, Koichi ;
Toyota Central R&D Labs., Inc., Nagakute, Aichi 480-1192, Japan

Bipolar/BiCMOS Circuits and Technology Meeting (BCTM), 2013 IEEE
<http://dx.doi.org/10.1109/BCTM.2013.6798163>

Many power switching devices are used in a hybrid vehicle (HV) and an electric vehicle (EV) systems. For future development of the HV/EV, higher performances than that of Si power devices, for example, low on-resistance, high speed, high operation temperature, are strongly required. GaN power devices are promising candidate for the requirements. Power modules used in HV/EV system and present status of the GaN power device development are presented. Reliability of the GaN power device was also discussed.

Improving off-state leakage characteristics for high voltage AlGaIn/GaN-HFETs on Si substrates

Sung-Woon Moon, John Twynam, Jongsub Lee, Deokwon Seo, Sungdal Jung, Hong Goo Choi, Heejae Shim, Jeong Soon Yim, Sungwon D. Roh
Components & Materials R&D Center, LG Innotek, Seoul 137-724, Republic of Korea

Solid-State Electronics
Volume 96, June 2014, Pages 19–21
<http://dx.doi.org/10.1016/j.sse.2014.03.011>

We present a reliable process and design technique for realizing high voltage AlGaIn/GaN hetero-junction field effect transistors (HFETs) on Si substrates with very low and stable off-state leakage current characteristics. In this work, we have investigated the effects of the surface passivation layer, prepared by low pressure chemical vapor deposition (LPCVD) of silicon nitride (SiN_x), and gate bus isolation design on the off-state leakage characteristics of metal-oxide-semiconductor (MOS) gate structure-based GaN HFETs. The surface passivated devices with gate

bus isolation fully surrounding the source and drain regions showed extremely low off-state leakage currents of less than 20 nA/mm at 600 V, with very small variation. These techniques were successfully applied to high-current devices with 80- μ m gate width, yielding excellent off-state leakage characteristics within a drain voltage range 0–700 V.

GaN Heterostructure Barrier Diodes Exploiting Polarization-Induced δ -Doping

Zhao, P. ; Verma, A. ; Verma, J. ; Xing, H.G. ; Fay, P. ; Jena, D.

Department of Electrical Engineering, University of Notre Dame, Notre Dame, IN 46556 USA.

Electron Device Letters, IEEE
<http://dx.doi.org/10.1109/LED.2014.2316140>

A GaN-based heterostructure barrier diode (HBD) similar to GaAs planar-doped barrier diodes is demonstrated. Instead of doping with impurities, the polarization-induced sheet charge at the III-nitride heterojunction behaves as an effective δ -doping. An AlGaIn/GaN heterostructure is used for the demonstration. The rectifying characteristics of the polarization-induced GaN HBDs can be tuned by controlling the graded AlGaIn thickness and composition. Such polarization-engineered HBDs can find applications in high-voltage and high-frequency electronics.

Degradation of AlGaIn/GaN high-electron mobility transistors in the current-controlled off-state breakdown

J. Kuzmik^{1,a}), M. Jurkovič¹, D. Gregušová¹, M. Ťapajna¹, F. Brunner², M. Cho², G. Meneghesso³ and J. Würfl²

¹ Institute of Electrical Engineering SAS, Dubravská cesta 9, 841 04 Bratislava, Slovakia

² Ferdinand-Braun-Institute, Leibnitz Institute für Hochfrequenztechnik, Gustav-Kirchoff-Strasse 4, 12489 Berlin, Germany

³ Department of Information Engineering, University of Padova, via Gradenigo, 6/B 35131 Padova, Italy

We investigate degradation mechanisms in AlGaIn/GaN HEMTs which were repeatedly driven into the current-controlled off-state breakdown or subject to 60 s voltage- or current-controlled off state stresses. The current-controlled sweep in to the breakdown allows the sustainability of breakdown that can not be observed in the voltage controlled sweep. Only temporal changes were observed in the HEMT dc performance after repetitive sweeps, which were explained by charging/discharging of the HEMT surface at the gate-to-drain access region and in the GaN buffer below the gate. Similar changes were observed also if high-voltage stress has been applied on the drain; however, permanent degradation appears after 60 s current-controlled breakdown stress. In this case, the drain leakage current, as well as the breakdown current, increases significantly. On the other hand, the breakdown voltage, as well as the gate characteristics, remains unaltered. We suggest that the avalanche-injection process is governing the off-state breakdown event with a dominant role of the potential barrier at the channel-buffer interface.

Low thermal budget Hf/Al/Ta ohmic contacts for InAlN/GaN-on-Si HEMTs with enhanced breakdown voltage

Yi Liu^{1,a}, Sarab Preet Singh², Yi Jie Ngoo², Lwin Min Kyaw², Milan Kumar Bera², Quo Qiang Lo³ and Eng Fong Chor^{4,b}

¹ Department of Electrical and Computer Engineering, National University of Singapore, Singapore 119074 and Institute of Microelectronics, Singapore 117685

² Department of Electrical and Computer Engineering, National University of Singapore, Singapore 119074

³ Institute of Microelectronics, Singapore 117685

⁴ Department of Electrical and Computer Engineering, National University of Singapore, Singapore 119074

Journal of Vacuum Science & Technology B
Vol. 32, 032201 (2014);
<http://dx.doi.org/10.1116/1.4874599>

The authors have studied the electrical characteristics of Hf/Al/Ta ohmic contacts on In_{0.18}Al_{0.82}N/GaN heterostructure grown on Si (111) substrate. With annealing at 600 °C in

vacuum (which is ~200 °C lower than that for traditional Ti/Al/Ni/Au contacts), a minimum ohmic contact resistance of ~0.58 Ω·mm and specific contact resistivity of ~6.75 × 10⁻⁶ Ω·cm² are obtained. The minimum contact resistance of Hf/Al/Ta contacts is comparable to that of Ti/Al/Ni/Au contacts. Owing to the lower annealing temperature, Hf/Al/Ta contacts exhibit better surface morphology and edge acuity. More importantly, Hf/Al/Ta contacts show a smooth interface with In_{0.18}Al_{0.82}N/GaN, whereas spike structures that penetrate the In_{0.18}Al_{0.82}N layer are observed for Ti/Al/Ni/Au contacts. As a result, the source-carrier-injection induced breakdown mechanism is reduced in the In_{0.18}Al_{0.82}N/GaN-on-Si high electron mobility transistors (HEMTs) with Hf/Al/Ta ohmic contacts, thereby leading to an improved three-terminal off-state breakdown voltage by about 100 V (~53.5% improvement), in comparison to Ti/Al/Ni/Au based HEMTs.

Characteristics of GaN and AlGaIn/GaN FinFETs

Ki-Sik Ima, Hee-Sung Kanga, Jae-Hoon Leeb, Sung-Jae Changc, Sorin Cristoloveanuc, Maryline Bawedind, Jung-Hee Leea,

a School of Electronics Engineering, Kyungpook National University, Daegu, Republic of Korea

b Discrete Development Team, System LSI, Samsung Electronics Co., Ltd., Giheung, Republic of Korea

c IMEP-LAHC, Grenoble Institute of Technology, Minatec, BP 257, 38016 Grenoble Cedex 1, France

d IES, University of Montpellier II, 34095 Montpellier, France

Solid-State Electronics

<http://dx.doi.org/10.1016/j.sse.2014.04.033>

AlGaIn/GaN FinFETs, with high quality atomic layer deposited (ALD) Al₂O₃ gate dielectric, have been fabricated. The devices have a two-dimensional electron gas (2DEG) channel formed at AlGaIn/GaN heterointerface and two sidewall GaN MOS channels. Two distinct transconductance peaks can be observed, one for the 2DEG channel and the other for the sidewall GaN MOS channels. On the other hand, we present heterojunction-free GaN FinFETs with junctionless configuration. The current flows through the volume of the heavily doped GaN fin rather than at the surface channel, which leads to superior off-state

performance and less drain-induced virtual substrate biasing (DIVSB) effect.

Recent advances on dielectrics technology for SiC and GaN power devices

F. Roccaforte, P. Fiorenza, G. Greco, M. Vivona, R. Lo Nigro, F. Giannazzo, A. Pattib, M. Saggiob
a Consiglio Nazionale delle Ricerche - Istituto per la Microelettronica e Microsistemi (CNR-IMM) Strada VIII 5, Zona Industriale Catania 95121, Italy
b STMicroelectronics-Stradale Primosole50 Catania 95121, Italy

Applied Surface Science
Volume 301, 15 May 2014, Pages 9–18
<http://dx.doi.org/10.1016/j.apsusc.2014.01.063>

Silicon carbide (SiC) and gallium nitride (GaN) devices are considered as optimal solutions to meet the requirements of the modern power electronics. In fact, they can allow an improved efficiency in energy conversion at high power, as required today in several strategic application fields (like consumer electronics, renewable energies technology, transportation, electric power distribution, etc.).

However, while in the last decades impressive progresses have been recorded both in SiC and GaN devices, the full exploitation of these materials has not been reached yet, due to some open technological key issues.

This paper reviews some recent advances in dielectrics technology currently adopted to optimize the performances of SiC and GaN transistors. In particular, in the case of SiC the discussion is focused on the optimization of SiO₂/SiC interfaces in 4H-SiC MOSFETs technology by passivation processes of the gate oxides. On the other hand, the current trends in dielectrics passivation for GaN-based HEMTs to limit the gate leakage and the current collapse are discussed."

OFF-State Degradation of AlGaIn/GaN Power HEMTs: Experimental Demonstration of Time-Dependent Drain-Source Breakdown

Meneghini, M. ; Cibir, G. ; Bertin, M. ; Hurkx, G.A.M. ; Ivo, P. ; Sonsky, J. ; Croon, J.A. ; Meneghesso, G. ; Zanoni, E.
Department of Information Engineering, University of Padova, Padova 35131, Italy.

Electron Devices, IEEE Transactions on
<http://dx.doi.org/10.1109/TED.2014.2318671>

This paper reports the experimental demonstration of a novel degradation mechanism of high-power AlGaIn/GaN high electron mobility transistors (HEMTs), that is, time-dependent drain-source breakdown. With current-controlled breakdown measurements and constant voltage stress experiments we demonstrate that: 1) when submitted to constant voltage stress, in the OFF-state, the HEMTs can show a significant degradation; 2) the degradation process is time-dependent, and consists of a measurable increase in subthreshold drain-source leakage; this effect is ascribed to the accumulation of positive charge in proximity of the gate, consistently with previous theoretical calculations; and 3) a catastrophic (and permanent) failure is observed for long stress times, possibly due to thermal runaway or to the increase in the electric field in proximity of the localized drain-source leakage paths.

Gate Recessed Quasi-Normally OFF Al₂O₃/AlGaIn/GaN MIS-HEMT With Low Threshold Voltage Hysteresis Using PEALD AlN Interfacial Passivation Layer

Hsieh, T.-E. ; Chang, E.Y. ; Song, Y.-Z. ; Lin, Y.-C. ; Wang, H.-C. ; Liu, S.-C. ; Salahuddin, S. ; Hu, C.C.
Department of Materials Science and Engineering, National Chiao Tung University, Hsinchu 300, Taiwan.

Electron Device Letters, IEEE
<http://dx.doi.org/10.1109/LED.2014.2321003>

In this letter, a gate recessed normally OFF AlGaIn/GaN MIS-HEMT with low threshold voltage hysteresis using Al₂O₃/AlN stack insulator is presented. The trapping effect of Al₂O₃/GaN interface was effectively reduced with the insertion of 2-nm AlN thin interfacial passivation layer grown by plasma enhanced atomic layer deposition. The device exhibits a threshold voltage of +1.5 V, with current density of 420 mA/mm, an OFF-state breakdown voltage of 600 V, and high ON/OFF drain current ratio of ~10⁹.

400-A (Pulsed) Vertical GaN p-n Diode With Breakdown Voltage of 700 V

Kizilyalli, I.C. ; Edwards, A.P. ; Nie, H. ; Bui-Quang, P. ; Disney, D. ; Bour, D.
Avogy, Inc., San Jose, CA 95134 USA.

Electron Device Letters, IEEE

<http://dx.doi.org/10.1109/LED.2014.2319214>

There is a great interest in monolithic GaN semiconductor devices with high current capability for power electronics. In this letter, large area vertical GaN p-n diodes fabricated on bulk GaN substrates are discussed. Diodes with areas as large as 16 mm² with breakdown voltages exceeding 700 V and pulsed (100 μs) currents approaching 400 A are reported. This is made possible for the first time in part due to the recent availability of improved quality bulk GaN substrates.

Capacitance properties and simulation of the AlGaIn/GaN Schottky heterostructure

Harmatha Ladislav, Stuchlíková Ľubica, Racko Juraj, Marek Juraj, Pecháček Juraj, Benko Peter, Nemeč Michal, Breza Juraj
Institute of Electronics and Photonics, Faculty of Electrical Engineering and Information Technology, Slovak University of Technology, Bratislava 812 19, Slovakia

Applied Surface Science

<http://dx.doi.org/10.1016/j.apsusc.2014.05.097>

The paper presents the results of capacitance measurements on GaN/AlGaIn/GaN Schottky heterostructures grown on an Al₂O₃ substrate by Low-Pressure Metal-Organic Vapour-Phase Epitaxy (LP-MOVPE). Dependences of the capacitance-voltage (CV) characteristics on the frequency of the measuring signal allow analysing the properties of the 2D electron gas (2DEG) at the AlGaIn/GaN heterojunction. Exact location of the hetero-interface below the surface (20 nm) was determined from the concentration profile. Temperature variations of the CV curves reveal the influence of bulk defects in GaN and of the traps at the AlGaIn/GaN interface. Electrical activity of these defects was characterized by capacitance Deep Level Transient Fourier

Spectroscopy (DLTFS). Experimental results of CV measurements were supported by simulating the properties of the GaN/Al_{0.2}Ga_{0.8}/GaN Schottky heterostructure in dependence on the influence of the concentration of donor-like traps in GaN and of the temperature upon the CV curves.

900 V/1.6 mΩ.cm² Normally Off Al₂O₃/GaN MOSFET on Silicon Substrate

Wang, M. ; Wang, Y. ; Zhang, C. ; Xie, B. ; Wen, C.P. ; Wang, J. ; Hao, Y. ; Wu, W. ; Chen, K.J. ; Shen, B.
Institute of Microelectronics, Peking University, Beijing, China

Electron Devices, IEEE Transactions on

Volume:61 , Issue: 6, Page(s):2035 - 2040

<http://dx.doi.org/10.1109/TED.2014.2315994>

In this paper, we report the device performance of a high-voltage normally off Al₂O₃/GaN MOSFET on the Si substrate. Normally off operation is obtained by multiple cycles of O₂ plasma oxidation and wet oxide-removal gate recess process. The recessed normally off GaN MOSFET with 3 μm gate-drain distance exhibits a maximum drain current of 585 mA/mm at 9 V gate bias. The threshold voltage of the MOSFET is 2.8 V with a standard derivation of 0.2 V on the sample with an area of 2x2 cm². The gate leakage current is below 10⁻⁶ mA/mm during the whole gate swing up to 9 V and the ION/IOFF ratio is larger than 10⁹, indicating the good quality of Al₂O₃ gate insulator. The MOSFET with 10 μm gate-drain distance shows a three terminal OFF-state breakdown voltage (BV) of 967 V at zero gate-source bias with a drain leakage current criterion of 1 μA/mm. The specific ON-resistance RON,SP of the device is 1.6 mΩ.cm² and the power figure of merit BV²/RON,SP is 584 MW/cm².

GROUP 4 - Advanced Electronics and RF

Group leader: Jean-Claude Dejaeger (IEMN)
Information selected by Jean-Claude Dejaeger (IEMN)

GaN RF device technology and applications, present and future

Green, Bruce ; Moore, Karen ; Hill, Darrell ; CdeBaca, Monica ; Schultz, Joe
RF, Freescale Semiconductor, Tempe, Arizona, USA

Bipolar/BiCMOS Circuits and Technology Meeting (BCTM), 2013 IEEE
<http://dx.doi.org/10.1109/BCTM.2013.6798154>

Over the last decade, Gallium Nitride (GaN) has emerged as a mainstream RF technology with disruptive performance potential. Here, we present GaN technology in the context of current commercial RF communications applications as well as future applications. We show state of the art >200W, >75% efficient packaged device performance at 2.14 GHz using a 0.6 μm 48 V technology and apply the device technology to a 400 W ultra-small footprint Doherty power amplifier. We also describe extending the 0.6 μm technology to a 0.2 μm gate length that allows for higher fT that will enable future technology for high-efficiency switch-mode amplifiers.

AlN thin-film deposition for suppressing surface current losses in RF circuits on high-resistivity silicon

Evseev, S.B. ; ; Nanver, L.K. ; Milosavljevic, S.
Dept. Microelectronics, Delft University of Technology, The Netherlands

Bipolar/BiCMOS Circuits and Technology Meeting (BCTM), 2013 IEEE
<http://dx.doi.org/10.1109/BCTM.2013.6798148>

Thin aluminum nitride (AlN) films, deposited by means of Physical Vapor Deposition (PVD) to a thickness up to 200 nm, are studied as RF passivation layers for transmission lines High Resistivity Silicon (HRS) substrates. Excellent passivation properties are demonstrated by measuring RF losses on coplanar waveguides (CPWs) as well as the space-charge-layer sheet resistance (SCL-RSH) on specially designed MISFET structures. Compared to oxide interfaces the

losses go from a strongly bias-dependent ~ 10 dB/cm to a bias-independent 1.7 dB/cm for the AlN:Si interfacial layer, corresponding to an increase of SCL-RSH from $\sim 104 \Omega/\square$ to $107 \Omega/\square$. The results suggest that a high resistive AlN:Si layer is formed by interdiffusion of the AlN and underlying Si which then conducts the parasitic interface currents.

Highly uniform AlGaIn/GaN HEMT films grown on 200-mm silicon substrates by plasma molecular beam epitaxy

William E. Hoke¹, Theodore D. Kennedy¹, Abbas Torabi¹, Peter S. Lyman¹, C. Alan Howsare¹ and Brian D. Schultz^{1,a}
Raytheon Company, Andover, Massachusetts 01810

Journal of Vacuum Science & Technology B
Vol. 32, 030605 (2014);
<http://dx.doi.org/10.1116/1.4873996>

Highly uniform AlGaIn/GaN HEMT films with good electron transport properties have been grown on 200-mm silicon substrates by plasma molecular beam epitaxy. X-ray diffraction measurements indicate an AlGaIn compositional and thickness variation of $\pm 1\%$ across the wafer, and a 29 point resistance map of a HEMT yielded a sheet resistance of $451 \Omega/\text{sq} \pm 1.1\%$. The electron mobility for seven measurements taken across the diameter of the wafer was $1555 \text{ cm}^2/\text{Vs} \pm 1\%$. The mobility obtained on 200-mm silicon is within 10% of the mobility obtained for GaN HEMTs grown on 100-mm SiC substrates, which have a much smaller lattice mismatch with GaN. The uniform films were obtained at GaN growth rates comparable to 100-mm growth and a chamber pressure well within the free molecular flow regime.

DC and RF characteristics of enhancement-mode InAlN/GaN HEMT with fluorine treatment

Song Xubo (宋旭波), Gu Guodong (顾国栋), Dun Shaobo (敦少博), Lü Yuanjie (吕元杰), Han Tingting (韩婷婷), Wang Yuangang (王元刚), Xu Peng (徐鹏) and Feng Zhihong (冯志红)
National Key Laboratory of ASIC, Hebei Semiconductor Research Institute, Shijiazhuang 050051, China

Journal of Semiconductors
Vol. 35, 044002
<http://dx.doi.org/10.1088/1674-4926/35/4/044002>

We report an enhancement-mode InAlN/GaN HEMT using a fluorine plasma treatment. The threshold voltage was measured to be +0.86 V by linear extrapolation from the transfer characteristics. The transconductance is 0 mS/mm at $V_{GS} = 0$ V and $V_{DS} = 5$ V, which shows a truly normal-off state. The gate leakage current density of the enhancement-mode device shows two orders of magnitude lower than that of the depletion-mode device. The transfer characteristics of the E-mode InAlN/GaN HEMT at room temperature and high temperature are reported. The current gain cut-off frequency (f_T) and the maximum oscillation frequency (f_{max}) of the enhancement-mode device with a gate length of 0.3 μm were 29.4 GHz and 37.6 GHz respectively, which is comparable with the depletion-mode device. A classical 16 elements small-signal model was deduced to describe the parasitic and the intrinsic parameters of the device.

Interface states in Al₂O₃/AlGa_N/Ga_N metal-oxide-semiconductor structure by frequency dependent conductance technique

Liao Xue-Yang (廖雪阳)^{1,2}, Zhang Kai (张凯)², Zeng Chang (曾畅)¹, Zheng Xue-Feng (郑雪峰)², En Yun-Fei (恩云飞)¹, Lai Ping (来萍)¹ and Hao Yue (郝跃)²
¹ Science and Technology on Reliability Physics and Application of Electronic Component Laboratory, the 5th Electronics Research Institute of the Ministry of Industry and Information Technology Guangzhou 510610, China
² Key Laboratory for Wide Band-Gap Semiconductor Materials and Devices, School of Microelectronics, Xidian University, Xi'an 710071, China

Chinese Physics B
Vol. 23; 057301
<http://dx.doi.org/10.1088/1674-1056/23/5/057301>

Frequency dependent conductance measurements are implemented to investigate the interface states in Al₂O₃/AlGa_N/Ga_N metal-oxide-semiconductor (MOS) structures. Two types of device structures, namely, the recessed gate structure (RGS) and the normal gate structure (NGS), are studied in the experiment. Interface trap parameters including trap density D_{it} , trap time constant τ_{it} , and trap state energy E_T in both devices have been determined. Furthermore, the obtained results demonstrate that the gate recess process can induce extra traps with shallower energy levels at the Al₂O₃/AlGa_N interface due to the damage on the surface of the AlGa_N barrier layer resulting from reactive ion etching (RIE).

AlGa_N/Ga_N heterostructure prepared on a Si (110) substrate via pulsed sputtering

T. Watanabe¹, J. Ohta¹, T. Kondo¹, M. Ohashi¹, K. Ueno¹, A. Kobayashi¹ and H. Fujioka^{1,2,a}
¹ Institute of Industrial Science (IIS), The University of Tokyo, 4-6-1 Komaba, Tokyo 153-8505, Japan
² CREST, Japan Science and Technology Corporation (JST), 5 Sanbancho, Chiyoda-ku, Tokyo 102-0075, Japan

Applied Physics Letters
Vol. 104, 182111 (2014)
<http://dx.doi.org/10.1063/1.4876449>

GaN films were grown on Si (110) substrates using a low-temperature growth technique based on pulsed sputtering. Reduction of the growth temperature suppressed the strain in the GaN films, leading to an increase in the critical thickness for crack formation. In addition, an AlGa_N/Ga_N heterostructure with a flat heterointerface was prepared using this technique. Furthermore, the existence of a two dimensional electron gas at the heterointerface with a mobility of 1360 cm²/Vs and a sheet carrier density of 1.3×10^{13} cm⁻² was confirmed. Finally, the use of the AlGa_N/Ga_N heterostructure in a high electron mobility transistor was demonstrated. These results indicate that low-temperature growth via pulsed sputtering is quite

promising for the fabrication of GaN-based electronic devices.

A Microwave Modeling Oxymoron?: Low-Frequency Measurements for Microwave Device Modeling

Nallatamby, J. ; Sommet, R. ; Jardel, O. ; Laurent, S. ; Prigent, M. ; Quere, R.
XLIM CNRS, University of Limoges, Brive, 19100, France

Microwave Magazine, IEEE
Volume:15, Issue: 4, Page(s): 92 - 107
<http://dx.doi.org/10.1109/MMM.2014.2308766>

For a number of decades, the modeling of microwave transistors relied on specific well-known characterization methods. Those methods include S-parameters measurement through vector network analyzers (VNAs) ranging from the lower end of the RF spectrum to the millimeter-wave (mm-wave) region and load pull measurements of transistors used for the design of power amplifiers (PAs). Later, the availability of more powerful computer-aided design (CAD) software enabled the need for models of active microwave devices, thus driving a huge amount of research activity on microwave transistor modeling. Simultaneously, new transistor technologies were invented, combining working concepts such as heterojunction bipolar transistors (HBTs), metal semiconductor field effect transistors (MESFETs) or high electron mobility transistors (HEMTs) and new materials such as gallium arsenide (GaAs), gallium nitride (GaN), indium phosphide (InP), and silicon germanium (SiGe), to cite only the main ones.

Two-dimensional electron gases in strained quantum wells for AlN/GaN/AlN double heterostructure field-effect transistors on AlN

Guowang Li¹, Bo Song¹, Satyaki Ganguly¹, Mingda Zhu¹, Ronghua Wang¹, Xiaodong Yan¹, Jai Verma¹, Vladimir Protasenko¹, Huili Grace Xing¹ and Debdeep Jena^{1,a})

Department of Electrical Engineering, University of Notre Dame, Indiana 46556, USA

Applied Physics Letters
Vol. 104, 193506 (2014)
<http://dx.doi.org/10.1063/1.4875916>

Double heterostructures of strained GaN quantum wells (QWs) sandwiched between relaxed AlN layers provide a platform to investigate the quantum-confined electronic and optical properties of the wells. The growth of AlN/GaN/AlN heterostructures with varying GaN quantum well thicknesses on AlN by plasma molecular beam epitaxy (MBE) is reported. Photoluminescence spectra provide the optical signature of the thin GaN QWs. Reciprocal space mapping in X-ray diffraction shows that a GaN layer as thick as ~28 nm is compressively strained to the AlN layer underneath. The density of the polarization-induced two-dimensional electron gas (2DEG) in the undoped heterostructures increases with the GaN QW thickness, reaching $\sim 2.5 \times 10^{13}/\text{cm}^2$. This provides a way to tune the 2DEG channel density without changing the thickness of the top barrier layer. Electron mobilities less than $\sim 400 \text{ cm}^2/\text{Vs}$ are observed, leaving ample room for improvement. Nevertheless, owing to the high 2DEG density, strained GaN QW field-effect transistors with MBE regrown ohmic contacts exhibit an on-current density $\sim 1.4 \text{ A/mm}$, a transconductance $\sim 280 \text{ mS/mm}$, and a cut off frequency $f_T \sim 104 \text{ GHz}$ for a 100-nm-gate-length device. These observations indicate high potential for high-speed radio frequency and high voltage applications that stand to benefit from the extreme-bandgap and high thermal conductivity of AlN.

GROUP 5 - Sensors and MEMS

Group leader: Marc Faucher (IEMN)

Information selected by Paul Leclaire (CRHEA-CNRS)

Microfluidic injector simulation with SAW sensor for 3D integration

Bui Thu, Hang ; ; Chu Duc, Trinh
Department of Microelectromechanical Systems and Microsystems, Faculty of Electronics and Telecommunications, University of Engineering and Technology, Vietnam National University, Hanoi, Vietnam

Sensors Applications Symposium (SAS), 2014 IEEE
<http://dx.doi.org/10.1109/SAS.2014.6798948>

The possible creation of efficient liquid sensors on the nozzle is presented. The proposed surface acoustic wave (SAW) device utilizing Aluminum Nitride (AlN) single crystal as the piezoelectric substrate is based on the pressure variation due to the continuous droplet ejector. The design, specification and numerical simulation results are described. Output response results demonstrating the efficiency and scalability of the method have been presented. This 3D integrated system has a number of advantages, such as sensitivity to droplet pressure in the nozzle. It is able to detect the start of the droplet formation process and is compatible with CMOS fabrication technology leading to an inexpensive and reliable system. The droplet generation process begins at an output voltage of roughly 0.074 V and the background level of the attenuation of both mechanical and electrical energy. Using a 3D model, the combination capacity between inkjet printer and piezoelectric and electrical-mechanical stability was verified.

Design-Dependent Performance of Self-actuated and Self-sensing Piezoelectric-AlN Cantilevers in Liquid Media Oscillating in the Fundamental in-plane Bending Mode

Martin Kucera, b, Elisabeth Wistrelaa, Georg Pfusterschmieda, Víctor Ruiz-Díezc, Tomás Manzanec, Jorge Hernando-Garcíac, José Luis Sánchez-Rojasc, Artur Jachimowicza, d, Johannes Schalkoa, Achim Bittnera, Ulrich Schmida

a Institute of Sensor and Actuator Systems, Vienna University of Technology, Floragasse 7, 1040 Vienna, Austria

b Austrian Center of Competence for Tribology, Viktor-Kaplan-Straße 2, 2700 Wr. Neustadt, Austria

c Group of Microsystems, Actuators and Sensors, E.T.S.I. Industriales, Universidad de Castilla-La Mancha, 13071 Ciudad Real, Spain

d Center for Integrated Sensor Systems, Danube University Krems, Viktor-Kaplan-Straße 2, 2700 Wr. Neustadt, Austria

Sensors and Actuators B: Chemical
<http://dx.doi.org/10.1016/j.snb.2014.04.048>

In this work the electrical performance of micromachined piezoelectric cantilevers having different designs is investigated in liquid environment, thus making most beneficial use of their self-actuated and self-sensing capability. The impact of parasitic effects originating from e.g. the electrical feedlines, on the sensing characteristics is discussed. The focus is set on in-plane bending modes excited in a large viscosity range from 1.09 cP to 238.82 cP and the corresponding influence on the conductance peak, which is important especially for liquid monitoring purposes. Furthermore, an analytical model for the dynamic admittance and the conductance peak is presented and compared to the measurements. Based on these results design guidelines for optimizing the performance of piezoelectric in-plane resonators are presented.

Solution-based functionalization of gallium nitride nanowires for protein sensor development

Elissa H. Williamsa, b, c, Albert V. Davydova, Vladimir P. Oleshkoa, Kristen L. Steffensa, Igor Levina, Nancy J. Lina, Kris A. Bertnessd, Amy K. Manocchie, John A. Schreifelsb, John A. Schreifelsb,
a Material Measurement Laboratory, National Institute of Standards and Technology, 100 Bureau Drive, Gaithersburg, MD 20899, USA
b Department of Chemistry and Biochemistry, George Mason University, 4400 University Drive, Fairfax, VA 22030, USA

c Department of Electrical and Computer Engineering, George Mason University, 4400 University Drive, Fairfax, VA 22030, USA

d Physical Measurement Laboratory, National Institute of Standards and Technology, 325 Broadway, Boulder, CO 80305, USA

e Sensors and Electronic Devices Directorate, Army Research Laboratory, 2800 Powder Mill Road, Adelphi, MD 20783, USA

Surface Science

<http://dx.doi.org/10.1016/j.susc.2014.04.010>

A solution-based functionalization method for the specific and selective attachment of the streptavidin (SA) protein to gallium nitride (GaN) nanowires (NWs) is presented. By exploiting streptavidin's strong affinity for its ligand biotin, SA immobilization on GaN NWs was achieved by exposing the GaN NW surface to a 3-aminopropyltriethoxysilane (APTES) solution followed by reaction with biotin. Functionalization of the NWs with APTES was facilitated by the presence of an ≈ 1 nm thick surface oxide layer, which formed on the NWs after exposure to air and oxygen plasma. Biotinylation was accomplished by reacting the APTES-functionalized NWs with sulfo-N-hydroxysuccinimide-biotin at slightly alkaline pH. It was determined that the biotinylated GaN NW surface was specific towards the binding of SA and demonstrated no affinity towards a control protein, bovine serum albumin (BSA). There was however, evidence of non-specific, electrostatic binding of both the SA protein and the BSA protein to the APTES-coated NWs, revealing the importance of the biotinylation step. Successful SA immobilization on the biotinylated GaN NW surface was verified using fluorescence microscopy, field-emission scanning electron microscopy, high-resolution transmission electron microscopy, atomic force microscopy, and x-ray photoelectron spectroscopy. The functionalized GaN NWs demonstrate potential as biosensing platforms for the selective detection of proteins.

Young's modulus extraction of epitaxial heterostructure AlGaIn/GaN for MEMS application

Achraf Ben Amar^{1,*}, Marc Faucher¹, Virginie Brandli¹, Yvon Cordier² and Didier Théron¹

¹IEMN, CNRS UMR 8520, Villeneuve d'Ascq Cedex, France

²CRHEA, CNRS UPR 10, Valbonne, France

Physica Status Solidi (a)

<http://dx.doi.org/10.1002/pssa.201330339>

This paper presents a Young's modulus extraction method for thin film group III-nitrides materials such as GaN, AlN, and its ternary AlGaIn. The AlGaIn/GaN heterostructures are grown by molecular beam epitaxy on Si (111) substrate and designed for MEMS applications. Various cantilevers with a width of 10 μm and lengths going from 100 to 310 μm were fabricated. The Young's moduli are determined using the resonance frequencies measured by laser Doppler vibrometry (LDV). Finite element modeling (FEM) is used to consider the under-etching of the cantilevers at the anchor. In this study, we find that the Young moduli of GaN and AlN layers are respectively 261 ± 60 GPa and 339 ± 78 GPa that compares well with the results found in the literature for bulk materials.

Sub-1-volt Piezoelectric Nanoelectromechanical Relays With Millivolt Switching Capability

Zaghloul, U. ; Piazza, G.

Department of Electrical and Computer Engineering, Carnegie Mellon University, Pittsburgh, PA 15213 USA

Electron Device Letters, IEEE

<http://dx.doi.org/10.1109/LED.2014.2318049>

The design, fabrication, and characterization of the first piezoelectric nanoelectromechanical relays with sub-1-volt actuation (520 mV) are presented. The low actuation voltage is enabled by employing ultrathin piezoelectric aluminum nitride films (10 nm) with high c-axis orientation and controlled residual stress in a stress-compensating geometry. Two different actuation methods based on optimized four-layer unimorph actuators are used to synthesize normally closed relays with high mechanical restoring forces. The first experimental demonstration of few millivolts switching (10 mV) using the realized relays is also presented. The relays exhibit a very low energy dissipation per switching cycle (23 aJ), an extremely small subthreshold slope (0.013

mV/decade), and a low ON-state resistance (2.3 k Ω).

High Precision, Electrochemical Detection of Reversible Binding of Recombinant Proteins on Wide Bandgap GaN Electrodes Functionalized with Biomembrane Models

Nataliya Frenkel^{1,2}, Jens Wallys⁴, Sara Lippert⁴, Jörg Teubert⁴, Stefan Kaufmann¹, Aparna Das⁵, Eva Monroy⁵, Martin Eickhoff^{4,*} and Motomu Tanaka^{1,2,3}
¹Physical Chemistry of Biosystems, Institute of Physical Chemistry, University of Heidelberg, Heidelberg, Germany
²Cell Biophysics Lab, Institute of Toxicology and Genetics, Karlsruhe Institute of Technology, Karlsruhe, Germany
³Institute for Integrated Cell-Material Science (WPI iCeMS), Kyoto University, Kyoto, Japan
⁴Physikalisches Institut, Justus-Liebig-Universität Gießen, Gießen, Germany
⁵CEA Grenoble, INAC/SP2M/NPSC, Grenoble 9, France

Advanced Functional Materials

<http://dx.doi.org/10.1002/adfm.201400388>

We report a novel hybrid charge sensor realized by the deposition of phospholipid monolayers on highly doped n-GaN electrodes. To detect the binding of recombinant proteins with histidine-tags, lipid vesicles containing chelator lipids were deposited on GaN electrodes pre-coated with octadecyltrimethoxysilane monolayers. Owing to its optical transparency, GaN allows the confirmation of the fluidity of supported membranes by fluorescence recovery after photobleaching (FRAP). The electrolyte-(organic) insulator-semiconductor (EIS) setup enables one to transduce variations in the surface charge density ΔQ into a change in the interface capacitance ΔC_p and, thus, the flat-band potential ΔU_{FB} . The obtained results demonstrate that the membrane-based charge sensor can reach a high sensitivity to detect reversible changes in the surface charge density on the membranes by the formation of chelator complexes, docking of eGFP with histidine tags, and cancellation by EDTA. The achievable resolution of $\Delta Q \geq 0.1 \mu\text{C}/\text{cm}^2$ is better than that obtained for membrane-functionalized p-GaAs, $0.9 \mu\text{C}/\text{cm}^2$, and for ITO coated with a polymer supported lipid monolayer, $2.2 \mu\text{C}/\text{cm}^2$.

Moreover, we examined the potential application of optically active InGaN/GaN quantum dot structures, for the detection of changes in the surface potential from the photoluminescence signals measured at room temperature.

Design-dependent performance of self-actuated and self-sensing piezoelectric-AlN cantilevers in liquid media oscillating in the fundamental in-plane bending mode

Martin Kucera^{a, b}, Elisabeth Wistrela^a, Georg Pfusterschmied^a, Víctor Ruiz-Díez^c, Tomás Manzaneque^c, Jorge Hernando-García^c, José Luis Sánchez-Rojas^c, Artur Jachimowicz^d, Johannes Schalko^a, Achim Bittner^a, Ulrich Schmida^a
^aInstitute of Sensor and Actuator Systems, Vienna University of Technology, Floragasse 7, 1040 Vienna, Austria
^bAustrian Center of Competence for Tribology, Viktor-Kaplan-Straße 2, 2700 Wiener Neustadt, Austria
^cGroup of Microsystems, Actuators and Sensors, E.T.S.I. Industriales, Universidad de Castilla-La Mancha, 13071 Ciudad Real, Spain
^dCenter for Integrated Sensor Systems, Danube University Krems, Viktor-Kaplan-Straße 2, 2700 Wiener Neustadt, Austria

Sensors and Actuators B: Chemical

Volume 200, September 2014, Pages 235–244

<http://dx.doi.org/10.1016/j.snb.2014.04.048>

In this work the electrical performance of micromachined piezoelectric cantilevers having different designs is investigated in liquid environment, thus making most beneficial use of their self-actuated and self-sensing capability. The impact of parasitic effects originating from e.g. the electrical feedlines, on the sensing characteristics is discussed. The focus is set on in-plane bending modes excited in a large viscosity range from 1.09 cP to 238.82 cP and the corresponding influence on the conductance peak, which is important especially for liquid monitoring purposes. Furthermore, an analytical model for the dynamic admittance and the conductance peak is presented and compared to the measurements. Based on these results design guidelines for optimizing the performance of piezoelectric in-plane resonators are presented.

Viscosity and density decoupling method using a higher order Lamb wave sensor

Tao Wang¹, Xiaojing Mu², Piotr Kropelnicki², Andrew Benson Randles² and Chengkuo Lee¹

¹ Department of Electrical and Computer Engineering, National University of Singapore, 4 Engineering Drive 3, 117576, Singapore

² Institute of Microelectronics (IME), Agency for Science, Technology and Research (A*STAR), 11 Science Park Road, 117685, Singapore

Journal of Micromechanics and Microengineering
Vol. 24; 075002

<http://dx.doi.org/10.1088/0960-1317/24/7/075002>

Viscosity and density are two important physical parameters of liquid. Such parameters are widely used for label-free chemical detection. Conventional technologies employ acoustic wave sensors to detect viscosity and density. In these sensors, the liquid under test directly contacts with the surface of the sensor. The produced acoustic wave in the sensor leaks to the adjacent liquid layer, causing a shift in the resonance frequency of the sensor. However, such sensors are not able to separately measure the viscosity and density because these two parameters jointly affect the shift of frequency. Although some indirect methods for decoupling these two parameters have been investigated, either dual-device or simultaneous measurement of frequency and attenuation is required. In this paper, a novel AIN based acoustic wave sensor is developed for decoupling viscosity and density. Multiple higher order modes of Lamb waves are generated in this sensor and employed to interact with the adjacent liquid under test. The frequency change of two unique modes (mode C and mode D) has been found in a linear relationship with viscosity and density, respectively. With this unique feature, viscosity and density of a liquid can be distinguished by a single device, which is promising for potential industrial applications, label-free chemical detection and clinical diagnosis.

GROUP 6 - Photovoltaics and Energy harvesting

Group leader: Eva Monroy (INAC-CEA)

Information selected by Knowmade

High-performance broadband optical coatings on InGaN/GaN solar cells for multijunction device integration

N. G. Young^{1,a}, E. E. Perl², R. M. Farrell¹, M. Iza¹, S. Keller², J. E. Bowers^{1,2}, S. Nakamura^{1,2}, S. P. DenBaars^{1,2} and J. S. Speck¹

¹ Materials Department, University of California, Santa Barbara, California 93106, USA

² Department of Electrical and Computer Engineering, University of California, Santa Barbara, California 93106, USA

Applied Physics Letters

Vol. 104, 163902 (2014);

<http://dx.doi.org/10.1063/1.4873117>

We demonstrate InGaN/GaN multiple quantum well solar cells grown by metalorganic chemical vapor deposition on a bulk (0001) substrate with high-performance broadband optical coatings to improve light absorption. A front-side anti-reflective coating and a back-side dichroic mirror were designed to minimize front surface reflections across a broad spectral range and maximize rear surface reflections only in the spectral range absorbed by the InGaN, making the cells suitable for multijunction solar cell integration. Application of optical coatings increased the peak external quantum efficiency by 56% (relative) and conversion efficiency by 37.5% (relative) under 1 sun AMO equivalent illumination.

Challenges for energy efficient wide band gap semiconductor power devices

Fabrizio Roccaforte^{1,*}, Patrick Fiorenza¹, Giuseppe Greco¹, Raffaella Lo Nigro¹, Filippo Giannazzo¹, Alfonso Patti² and Mario Saggio²

¹ Consiglio Nazionale delle Ricerche, Istituto per la Microelettronica e Microsistemi (CNR-IMM), Zona Industriale, Catania, Italy

² STMicroelectronics, Catania, Italy

Physica Status Solidi (a)

<http://dx.doi.org/10.1002/pssa.201300558>

Wide band gap semiconductors, and in particular silicon carbide (4H-SiC) and gallium nitride (GaN), are very promising materials for the next generation of power electronics, to guarantee an improved energy efficiency of devices and modules. As a matter of fact, in the last decade intensive academic and industrial research efforts have resulted in the demonstration of both 4H-SiC MOSFETs and GaN HEMTs exhibiting inline image/Ron performances well beyond the silicon limits.

In this paper, some of the present scientific challenges for SiC and GaN power devices technology are reviewed. In particular, the topics selected in this work will be the SiO₂/SiC interface passivation processes to improve the channel mobility in 4H-SiC MOSFETs, the current trends for gate dielectrics in GaN technology and the viable routes to obtain normally-off HEMTs."

Improved performance of dye-sensitized solar cells using gallium nitride–titanium dioxide composite photoelectrodes

Yin-Rou Huang, Tzu-Wei Huang, Tzu-Hui Wang, Yu-Chen Tsai

Department of Chemical Engineering, National Chung Hsing University, 250, Kuo Kuang Road, Taichung 402, Taiwan

Journal of Colloid and Interface Science

Volume 428, 15 August 2014, Pages 128–132

<http://dx.doi.org/10.1016/j.jcis.2014.04.042>

Dye-sensitized solar cells (DSSCs) are fabricated with gallium nitride–titanium dioxide (GaN–TiO₂) composite photoelectrodes to enhance the power conversion efficiency. The value of power conversion efficiency increases with the incorporation of GaN in TiO₂ matrix and reaches a maximum at 0.05 wt% GaN. Internal resistance in the DSSC is characterized by electrochemical impedance spectroscopy (EIS). From the EIS of electrolyte/dye/GaN–TiO₂ interface resistances under illumination and in the dark, a decrease in the charge transfer resistance and an increase in the charge recombination resistance of the DSSCs

are obtained after the inclusion of GaN (0.01–0.05 wt%) in the TiO₂ matrix. The power conversion efficiency of the DSSC based on the GaN (0.05 wt%)-TiO₂ composite photoelectrode is enhanced by ~61% in comparison with a pristine TiO₂ photoelectrode.

GaN nanowires for piezoelectric generators

N. Gogneau, P. Chrétien, E. Galopin, S. Guilet, L. Travers, J-C. Harmand and F. Houzé
Lpn

Physica Status Solidi (RRL) - Rapid Research Letters
Volume 8, Issue 5, May 2014
<http://dx.doi.org/10.1002/pssr.201470527>

The semiconductor nanowires (NWs) presenting piezoelectric properties have recently emerged as excellent candidates to fabricate novel and efficient piezoelectric generators through the harvesting of mechanical deformations and vibrations energies. In particular, gallium nitride (GaN) NWs are characterized by both higher piezoelectric response and output voltages with respect to other piezoelectric material NWs. In their Letter on pp. 414–419, Noelle Gogneau et al. investigate the mechanical–electrical conversion of GaN NWs. An average output voltage of about –74 mV for a large NW ensemble and a maximum output voltage reaching –443 mV ($\pm 2\%$) per NW are demonstrated. This latter output voltage is the highest value reported so far for GaN NWs. Based on these measured output signals, an average and a maximum power density generated by one layer of GaN NWs of the order of 5.9 mW/cm² and 130 mW/cm², respectively, have been estimated. This result evidences the strong potentiality of GaN NWs to develop ultra-compact and integrable renewable energy source for sustainable, independent and maintenance-free operation of microdevices.

Improved efficiency and stability of GaN photoanode in photoelectrochemical water splitting by NiO cocatalyst

S.H. Kim, M. Ebaid, J-H. Kang, S-W. Ryu
Department of Physics, Chonnam National University,
Gwangju 500-757, Korea

Applied Surface Science
Volume 305, 30 June 2014, Pages 638–641

<http://dx.doi.org/10.1016/j.apsusc.2014.03.151>

The NiO cocatalyst was deposited on a GaN photoanode to improve the water splitting efficiency and to stabilize the photoelectrolysis of the GaN photoanode without corrosion of the GaN layer. The photoanode performance was investigated for various NiO deposition conditions based on metal organic decomposition. The GaN photoanode with the optimized NiO morphology showed significantly improved efficiency and photocurrent stability during water splitting compared to the reference GaN. No corrosion was observed for the GaN photoanode combined with NiO, which confirmed that the enhanced stability was related to the suppressed GaN etching at the surface. The improved water splitting performance was attributed to the fast transport of photo-generated holes in the valence band from GaN to NiO and the efficient water reduction at the NiO/electrolyte interface.

Effects of quantum well number on spectral response of InGaN/GaN multiple quantum well solar cells

J. Yang, D. G. Zhao*, D. S. Jiang, P. Chen, Z. S. Liu, L. C. Le, X. G. He, X. J. Li and H. Yang
State Key Laboratory on Integrated Optoelectronics,
Institute of Semiconductors, Chinese Academy of
Sciences, Haidian District, Beijing 100083, P. R. China

Physica Status Solidi (a)
<http://dx.doi.org/10.1002/pssa.201431086>

Effects of quantum well number on spectral response of InGaN/GaN multiple quantum well (MQW) solar cells are investigated. It is found that the strain relaxation by forming defects occurs when the number of quantum wells (QWs) increases to 30. It results in the low luminescence intensity and external quantum efficiency (EQE) due to the poor crystal quality of MQW region and the high non-radiative recombination rate in MQW region. However, the EQE of 25-period InGaN/GaN MQW solar cell with relatively high crystal quality of MQW region does not increase at all wavelengths compared with 15-period one. This may be attributed to the lower carrier collection efficiency resulting from the lower electric field of i-MQW region.

GROUP 7 - Materials, Technology and Fundamental

Group leader: Jean-Christophe Harmand (LPN-CNRS)

NANO

Information selected by Jean-Christophe Harmand
(LPN-CNRS)

Statistical Analysis of the Shape of One-Dimensional Nanostructures: Determining the Coalescence Degree of Spontaneously Formed GaN Nanowires

Oliver Brandt *, Sergio Fernández-Garrido , Johannes K. Zettler , Esperanza Luna , Uwe Jahn , Caroline Chèze , and Vladimir M. Kaganer
Paul-Drude-Institut für Festkörperelektronik,
Hausvogteiplatz 5-7, 10117 Berlin, Germany

Crystal Growth & Design

<http://dx.doi.org/10.1021/cg401838q>

Single GaN nanowires formed spontaneously on a given substrate represent nanoscopic single crystals free of any extended defects. However, due to the high area density of thus formed GaN nanowire ensembles, individual nanowires coalesce with others in their immediate vicinity. This coalescence process may introduce strain and structural defects, foiling the idea of defect-free material due to the nanowire geometry. To investigate the consequences of this process, a quantitative measure of the coalescence of nanowire ensembles is required. We derive objective criteria to determine the coalescence degree of GaN nanowire ensembles. These criteria are based on the area–perimeter relationship of the cross-sectional shapes observed and in particular on their circularity. Employing these criteria, we distinguish single nanowires from coalesced aggregates in an ensemble, determine the diameter distribution of both, and final

Coherent nanocavity structures for enhancement in internal quantum efficiency of III-nitride multiple quantum wells

T. Kim¹, B. Liu¹, R. Smith¹, M. Athanasiou¹, Y. Gong¹ and T. Wang^{1,a})

¹ Department of Electronic and Electrical Engineering, University of Sheffield, Mappin Street, Sheffield S1 3JD, United Kingdom

Applied Physics Letters

Vol. 104, 161108 (2014);

<http://dx.doi.org/10.1063/1.4873161>

A “coherent” nanocavity structure has been designed on two-dimensional well-ordered InGaN/GaN nanodisk arrays with an emission wavelength in the green spectral region, leading to a massive enhancement in resonance mode in the green spectra region. By means of a cost-effective nanosphere lithography technique, we have fabricated such a structure on an InGaN/GaN multiple quantum well epiwafer and have observed the “coherent” nanocavity effect, which leads to an enhanced spontaneous emission (SE) rate. The enhanced SE rate has been confirmed by time resolved photoluminescence measurements. Due to the coherent nanocavity effect, we have achieved a massive improvement in internal quantum efficiency with a factor of 88, compared with the as-grown sample, which could be significant to bridge the “green gap” in solid-state lighting.

Growth, structural and optical properties of ternary InGaN nanorods prepared by selective-area metalorganic chemical vapor deposition

Jie Song, Benjamin Leung, Yu Zhang and Jung Han
Department of Electrical Engineering, Yale University,
New Haven, CT 06511, USA

Nanotechnology

Vol. 25; 3225602

<http://dx.doi.org/10.1088/0957-4484/25/22/225602>

Ternary InGaN nanorods were prepared on dielectric-masked nano-holes with selective area metalorganic chemical vapor deposition. To overcome the tendency for random nucleation of GaN at low temperatures, a pulsed growth procedure was introduced to enhance the diffusion length of Ga adatoms on SiO₂, resulting in good selectivity at typical temperature ranges for InGaN. Photoluminescence from the InGaN nanorods can be tuned from near ultraviolet (400 nm) to blue-green (~500 nm). Microstructural properties were characterized by transmission

electron microscopy; threading dislocations from the underlying GaN template were terminated at the nanorod/template interface, resulting in dislocation-free nanorods. The height of dislocation-free InGaN nanorods is about 150 nm, which is much larger than the critical thickness for the onset of misfit dislocations in planar InGaN growth with typical thickness of less than 10 nm for an indium composition between 10 and 20%. The composition profile of In along the growth direction was examined by energy dispersive x-ray spectroscopic mapping and line scan. Oscillations of In composition along the growth direction were observed and are likely due to the kinetic competition between In and Ga adatoms. These InGaN nanorods are expected to be useful as templates for growing higher In composition nano-light-emitting diodes.

Surface Effects on the Electrostatic Potential Generated in a Bent Gallium Nitride Nanowire

Zhang, J. ; Wang, C. ; Adhikari, S.
College of Engineering, Swansea University, Swansea, U.K.

Nanotechnology, IEEE Transactions on
Volume:13 , Issue: 3, Page(s): 600 - 606
<http://dx.doi.org/10.1109/TNANO.2014.2313837>

The aim of this paper is to conduct the first study of the surface effects on the voltage output of bent gallium nitride (GaN) nanowires (NWs), which are promising for nanogenerators. To reach this goal, a 3-D composite beam model was developed and the corresponding theoretical framework was established for the structural responses of piezoelectric NWs. In this study molecular dynamics simulations (MDS) were first carried out to determine the exact material properties for several small NW samples. The MDS-derived size-dependence of parameters provide fitting points for the 3-D composite beam with a core-shell geometry. With the aid of the finite element techniques the equivalent material properties obtained from above fitting procedure enable the use of the core-shell model for larger structures where MDS were not feasible. The obtained results showed that the influence of the surface layer greatly modifies the potential distribution on the cross section and raises the

voltage output of bent GaN NWs by up to 120%. In particular, the contribution from the surface piezoelectricity to the surface effect is found to be predominant over that of the surface elasticity and surface stresses.

Photo-Induced Conversion of Methane into Benzene over GaN Nanowires

Lu Li , Shizhao Fan , Xiaoyue Mu , Zetian Mi , and Chao-Jun Li

†Department of Chemistry, McGill University, 801 Sherbrooke Street West, Montreal, QC H3A 0B8, Canada

‡Department of Electrical and Computer Engineering, McGill University, 3480 University Street, Montreal, QC H3A 0E9, Canada

Journal of the American Chemical Society

<http://dx.doi.org/10.1021/ja5004119>

As a class of the key building blocks in the chemical industry, aromatic compounds are mainly derived from the catalytic reforming of petroleum-based long chain hydrocarbons. The dehydroaromatization of methane can also be achieved by using zeolitic catalysts under relative high temperature. Herein we demonstrate that Si-doped GaN nanowires (NWs) with 97% rationally constructed m-plane can directly convert methane into benzene and molecule hydrogen under ultraviolet (UV) illumination at room temperature. Mechanistic studies suggest that the exposed m-plane of GaN exhibited particularly high activity toward methane C-H bond activation and the quantum efficiency increased linearly as a function of light intensity. The incorporation of Si-donor or Mg-acceptor dopants into GaN also has a large influence on the photocatalytic performance.

GaN nanowires for piezoelectric generators

Noelle Gogneau, Pascal Chrétien, Elisabeth Galopin, Stéphane Guilet, Laurent Travers, Jean-Christophe Harmand and Frédéric Houzé
Lpn

Physica Status Solidi (RRL) - Rapid Research Letters
Volume 8, Issue 5, May 2014
<http://dx.doi.org/10.1002/pssr.201470527>

The semiconductor nanowires (NWs) presenting piezoelectric properties have recently emerged as

excellent candidates to fabricate novel and efficient piezoelectric generators through the harvesting of mechanical deformations and vibrations energies. In particular, gallium nitride (GaN) NWs are characterized by both higher piezoelectric response and output voltages with respect to other piezoelectric material NWs. In their Letter on pp. 414–419, Noelle Gogneau et al. investigate the mechanical–electrical conversion of GaN NWs. An average output voltage of about –74 mV for a large NW ensemble and a maximum output voltage reaching –443 mV ($\pm 2\%$) per NW are demonstrated. This latter output voltage is the highest value reported so far for GaN NWs. Based on these measured output signals, an average and a maximum power density generated by one layer of GaN NWs of the order of 5.9 mW/cm² and 130 mW/cm², respectively, have been estimated. This result evidences the strong potentiality of GaN NWs to develop ultra-compact and integrable renewable energy source for sustainable, independent and maintenance-free operation of microdevices.

Integrated photonic platform based on InGaN/GaN nanowire emitters and detectors

Maria Tchernycheva , Agnès Messanvi , Andres de Luna Bugallo , Gwenole Jacopin , Pierre Lavenus , Lorenzo Rigutti , Hezhi Zhang , Yacine Halioua , François H. Julien , Joel Eymery , and Christophe Durand

Nano Letters

<http://dx.doi.org/10.1021/nl501124s>

We report on the fabrication of a photonic platform consisting of single wire light emitting diodes (LED) and photodetectors optically coupled by waveguides. MOVPE-grown InGaN/GaN p-n junction core-shell nanowires have been used for device fabrication. To achieve a good spectral matching between the emission wavelength and the detection range, different active regions containing either five narrow InGaN/GaN quantum wells or one wide InGaN segment were employed for the LED and detector, respectively. The communication wavelength is 400 nm. The devices are realized by means of electron beam lithography on Si/SiO₂ templates and connected by 100 μ m long non-rectilinear SiN waveguides. The photodetector current trace shows signal

variation correlated with the LED on/off switching with a fast transition time below 0.5 sec.

Direct imaging of p-n junction in core-shell GaN wires

Pierre Tchoulfian , Fabrice Donatini , François Levy , Amélie Dussaigne , Pierre Ferret , and Julien Pernot

Nano Letters

<http://dx.doi.org/10.1021/nl5010493>

While core-shell wire-based devices offer a promising path toward improved optoelectronic applications, their development is hampered by the present uncertainty about essential semiconductor properties along the three-dimensional (3D) buried p-n junction. Thanks to a cross-sectional approach, scanning electron beam probing techniques were employed here to obtain a nanoscale spatially-resolved analysis of GaN core-shell wire p-n junctions grown by catalyst-free metal-organic vapour phase epitaxy on GaN and Si substrates. Both electron beam induced current (EBIC) and secondary electron voltage contrast (VC) were demonstrated to delineate the radial and axial junction existing in the 3D structure. The Mg dopant activation process in p-GaN shell was dynamically controlled by the ebeam exposure conditions and visualized thanks to EBIC mapping. EBIC measurements were shown to yield local minority carrier/exciton diffusion lengths on the p-side (57nm) and the n-side (15 nm) as well as depletion width in the range 40-50 nm. Under reverse bias conditions, VC imaging provided electrostatic potential maps in the vicinity of the 3D junction, from which acceptor Na and donor Nd doping levels were locally determined to be $N_a = 3 \times 10^{18} \text{ cm}^{-3}$ and $N_d = 3.5 \times 10^{18} \text{ cm}^{-3}$ in both the axial and the radial junction. Results from EBIC and VC are in good agreement. This nanoscale approach provides essential guidance to the further development of core-shell wire devices.

Physical properties and applications of InGa_{1-x}N nanowires

J. Segura-Ruiz¹, M. Gómez-Gómez², N. Garro², G. Martínez-Criado³, A. Cantarero⁴, C. Denker⁵, J. Malindretos⁵ and A. Rizzi⁵

¹ Materials Science Institute, University of Valencia, PO Box 22085, 46071 Valencia, Spain and European

Synchrotron Radiation Facility, Experiments Division,
38043 Grenoble, France
2 Materials Science Institute, University of Valencia, PO
Box 22085, 46071 Valencia, Spain
3 European Synchrotron Radiation Facility, Experiments
Division, 38043 Grenoble, France
4 Materials Science Institute, University of Valencia, PO
Box 22085, 46071 Valencia, Spain
5 Georg-August-University Göttingen, IV. Physikalisches
Institut, 37077 Göttingen, Germany

AIP Conference Proceedings
Vol. 1598, 103 (2014);
<http://dx.doi.org/10.1063/1.4878288>

We have successfully grown $\text{In}_x\text{Ga}_{1-x}\text{N}$ nanowires by plasma-assisted molecular beam epitaxy on silicon substrates. The alloy composition and crystal quality have been analyzed by Raman scattering, photoluminescence spectroscopy and x-ray fluorescence nanoprobe techniques. $\text{In}_x\text{Ga}_{1-x}\text{N}$ is an one-mode alloy, where the different optical modes have an intermediate frequency of that of pure InN and GaN . The sample composition can be derived from the Raman data. On the other hand, by using the optical gap provided by the emission spectra, we conclude that the samples have a lower Ga content than that provided by the Raman analysis. X-ray fluorescence maps and photoluminescence measured in single nanowires help to explain this contradictory result.

Light confinement in hexagonal GaN nanodisk with whispering gallery mode

Tetsuya Kouno¹, Masaru Sakai², Katsumi Kishino³ and Kazuhiko Hara¹

¹ Department of Electronics and Material Science, Shizuoka University, Hamamatsu 432-8011, Japan
² Interdisciplinary Graduate School of Medicine and Engineering, University of Yamanashi, Kofu 400-8511, Japan
³ Department of Engineering and Applied Sciences, Sophia University, Chiyoda, Tokyo 102-8554, Japan

Japanese Journal of Applied Physics
Vol. 53; 068005
<http://dx.doi.org/10.7567/JJAP.53.068005>

We demonstrated light confinement in hexagonal GaN nanodisks. The nanodisks were fabricated by crystal growth via radio-frequency plasma-

assisted molecular beam epitaxy, and the side length of the nanodisks was approximately 300 nm. Sharp peaks appeared at a wavelength of approximately 370 nm in the room-temperature photoluminescence spectrum of the nanodisks, indicating that the nanodisks acted as an optical nanoresonator. In addition, the results obtained by a finite-difference time domain method suggest that the resonant mode acting preferentially in such nanodisks is the whispering gallery mode. These results indicate that the GaN-based simple nanostructures can be used for nanolasers.

Structure and optical investigation of faceted hexagonal aluminum nitride nanotube arrays

Huajun Li¹, Xu Ji³, Zhiguo Wu¹, Hairong Hu¹, De Yan¹, Renfu Zhuo¹, Juanjuan Feng¹, Baisong Geng¹ and Pengxun Yan^{1,2}

¹ School of Physical Science and Technology, Lanzhou University, Lanzhou 730000, China
² Key Laboratory of Solid Lubrication, Institute of Chemistry and Physics, Chinese Academy of Science, Lanzhou 730000, China
³ State Key Laboratory of Optoelectronic Materials and Technologies, School of Physics and Engineering, Sun Yat-Sen University, Guangzhou 510275, China

Applied Physics Express
Vol. 7; 065003
<http://dx.doi.org/10.7567/APEX.7.065003>

Arrays of single-crystalline aluminum nitride nanotubes (AlNNTs) were successfully synthesized at 780 °C by a facile CVD method without templates or catalysts. Faceted hexagonal AlNNTs with diameters from tens to hundreds of nanometers were observed. 264 nm deep-ultraviolet emission associated with Al vacancies was detected by photoluminescence. Raman characterization indicates that the lattice of the AlNNTs is notably defective, and disorder-activated silent B₁ (low) and B₁ (high) were detected at 583.0 and 730.0 cm^{-1} respectively, which were allowed by the breakdown of the translational crystal symmetry. The redshift of E₂ (high) Raman modes indicates that biaxial tensile stress exists in the samples.

NON/SEMI POLAR

Information selected by Philippe De Mierry
(CRHEA-CNRS)

Ohmic contact to nonpolar a-plane p-type GaN using Ni/Au

Jae-Kwan Kim¹, Dong-min Lee^{1,6}, Sung-Nam Lee², Keun-Man Song³, Jae-Sik Yoon⁴ and Ji-Myon Lee⁵
¹ Department of Materials Science and Metallurgical Engineering, Suncheon National University, Suncheon, Chonnam 540-742, Korea
² Department of Nano-Optical Engineering, Korea Polytechnic University, Siheung, Gyeonggi 429-793, Korea
³ Korea Advanced Nano Fab Center (KANC), Suwon, Gyeonggi 443-270, Korea
⁴ Division of Materials Science, Korea Basic Science Institute, Daejeon 305-333, Korea
⁵ Department of Printed Electronics Engineering, Suncheon National University, Suncheon, Chonnam 540-742, Korea
⁶ Present address: Sapphire Artists Co., Ltd., Yongin, Gyeonggi 449-832, Korea.

Japanese Journal of Applied Physics
Vol. 53; 05HA04
<http://dx.doi.org/10.7567/JJAP.53.05HA04>

In this study, we examined the characteristics of Ni/Au (20 nm/80 nm) ohmic contacts to non-polar a-plane p-GaN as a function of annealing temperature. The current-voltage (I-V) curves were showed an upward curve with annealing when Ni/Au metals were used as ohmic metals to nonpolar p-GaN, which was similar to those of the other crystalline planes. The contact resistivity decreased from 2.36 to $6.95 \times 10^{-3} \Omega \text{ cm}^2$. Secondary ion mass spectroscopy showed that the Ga atoms out-diffused from the GaN substrate after annealing at 400 °C, which led to the generation of Ga vacancies. The formation of Ga and N vacancies was found to be a competing process during annealing.

Analysis of crystal orientation in AlN layers grown on m-plane sapphire

A. Mogilatenkoa, b, H. Kirmseb, J. Stellmachc, M. Frentrupc, F. Mehnkec, T. Wernickec, M. Kneissla, c, M. Weyersa
a Ferdinand-Braun-Institut, Leibniz-Institut fuer Hoehstfrequenztechnik, Berlin, Germany
b Humboldt Universitaet zu Berlin, Institut fuer Physik, Berlin, Germany

c Institut für Festkoerperphysik, Technische Universitaet Berlin, Berlin, Germany

Journal of Crystal Growth
<http://dx.doi.org/10.1016/j.jcrysgro.2014.04.014>

Our study reports on the microstructure of AlN layers grown on m-plane sapphire by metal organic vapor phase epitaxy. We have found that AlN can nucleate with three different orientations on the m-plane sapphire surface: semipolar (1 1 2 2) and (1 1 0 3) as well as m-plane (1 1 0 0). Depending on the growth conditions, i.e. V/III ratio, the differently oriented crystallites exhibit different lateral and vertical growth rates. At a low V/III ratio of 626 the vertical growth rate of semipolar (1 1 2 2) AlN regions is much lower than that of the (1 1 0 3) and (1 1 0 0) oriented grains, which results in an almost complete lateral overgrowth of the (1 1 2 2) AlN oriented regions. In contrast, a high V/III ratio of 1043 leads to the formation of uniform semipolar (1 1 2 2) AlN layers. Nevertheless, the formation of differently oriented AlN crystallites could not be suppressed completely. These randomly appearing crystallites still show a high vertical growth rate and lead to a deterioration of the surface morphology.

Hexagonal GaN microdisk with wurtzite/zinc-blende GaN crystal phase nano-heterostructures and high quality zinc-blende GaN crystal layer

Tetsuya Kouno¹, Masaru Sakai², Katsumi Kishino³ and Kazuhiko Hara¹
¹ Department of Electronics and Material Science, Shizuoka University, Hamamatsu 432-8011, Japan
² Interdisciplinary Graduate School of Medicine and Engineering, University of Yamanashi, Kofu 400-8511, Japan
³ Department of Engineering and Applied Sciences, Sophia University, Chiyoda, Tokyo 102-8554, Japan

Japanese Journal of Applied Physics
Vol. 53; 068001
<http://dx.doi.org/10.7567/JJAP.53.068001>

We revealed that a hexagonal GaN microdisk exhibiting lasing action at a wavelength of approximately 390 nm has peculiar crystal structures consisting of wurtzite (WZ)/zinc-blende (ZB) GaN crystal phase nano-heterostructures and a high-quality ZB GaN crystal layer. Upon transmission electron microscopy measurement,

5–20 monolayer ZB GaN nanocrystals were observed in the WZ GaN crystals in the microdisk, and approximately 250-nm-thick ZB crystals with no dislocations were observed in the upper part of the microdisk. The result indicates that the optical gain of the lasing action at a wavelength of approximately 390 nm is based on ZB GaN crystals.

Confirmation of intrinsic electron gap states at nonpolar GaN(1-100) surfaces combining photoelectron and surface optical spectroscopy

M. Himmerlich^{1,a}), A. Eisenhardt¹, S. Shokhovets¹, S. Krischok¹, J. Räthel², E. Speiser², M. D. Neumann², A. Navarro-Quezada² and N. Esser²

¹ Institut für Physik and Institut für Mikro- und Nanotechnologien, TU Ilmenau, PF 100565, 98684 Ilmenau, Germany

² Leibniz-Institut für Analytische Wissenschaften - ISAS - e.V., Albert-Einstein-Strasse 9, 12489 Berlin, Germany

Applied Physics Letters

Vol. 104, 171602 (2014);

<http://dx.doi.org/10.1063/1.4873376>

The electronic structure of GaN(1–100) surfaces is investigated in-situ by photoelectron spectroscopy (PES) and reflection anisotropy spectroscopy (RAS). Occupied surface states 3.1 eV below the Fermi energy are observed by PES, accompanied by surface optical transitions found in RAS around 3.3 eV, i.e., below the bulk band gap. These results indicate that the GaN(1–100) surface band gap is smaller than the bulk one due to the existence of intra-gap states, in agreement with density functional theory calculations. Furthermore, the experiments demonstrate that RAS can be applied for optical surface studies of anisotropic crystals.

Self-regulated in-plane polarity of [11̄00]-oriented GaN domains coalesced from twins grown on a SiO₂-patterned m-plane sapphire substrate

Hyemi Lee¹, Miyeon Jue¹, Hansub Yoon¹, Sanghwa Lee¹ and Chinkyoo Kim^{1,a})

Department of Physics and Research Institute for Basic Sciences, Kyung Hee University, 26 Kyunghee-daero, Dongdaemun-gu, Seoul 130-701, South Korea

Applied Physics Letters

Vol. 104, 182105 (2014);

<http://dx.doi.org/10.1063/1.4873545>

In-plane polarity of [11̄00] -oriented GaN domains coalesced from twins grown on a SiO₂-patterned m-plane sapphire substrate was observed to be self-regulated in such a way that basal faces of coalesced domains were mainly found to have the (0001̄) polarity only. This self-regulation behavior of in-plane polarity was explained by a computational simulation of plan-view surface morphology evolution during coalescence of twins. Based on a computational simulation, asymmetrically suppressed growth rates of twins near a SiO₂ pattern were proposed to be responsible for the survival of the slower growing (0001̄) basal faces instead of the faster growing (0001) basal faces during coalescence of twins.

Analysis of crystal orientation in AlN layers grown on m-plane sapphire

A. Mogilatenkoa, b, H. Kirmseb, J. Stellmachc, M.

Frentrupc, F. Mehnkec, T. Wernickec, M. Kneissla, c, M. Weyersa

a Ferdinand-Braun-Institut, Leibniz-Institut für Höchstfrequenztechnik, Berlin, Germany

b Humboldt Universität zu Berlin, Institut für Physik, Berlin, Germany

c Institut für Festkörperphysik, Technische Universität Berlin, Berlin, Germany

Journal of Crystal Growth

Volume 400, 15 August 2014, Pages 54–60

<http://dx.doi.org/10.1016/j.jcrysgro.2014.04.014>

Our study reports on the microstructure of AlN layers grown on m-plane sapphire by metal organic vapor phase epitaxy. We have found that AlN can nucleate with three different orientations on the m-plane sapphire surface: semipolar (1122) and (1103) as well as m-plane (1100). Depending on the growth conditions, i.e. V/III ratio, the differently oriented crystallites exhibit different lateral and vertical growth rates. At a low V/III ratio of 626 the vertical growth rate of semipolar (1122) AlN regions is much lower than that of the (1103) and (1100) oriented grains, which results in an almost complete lateral overgrowth of the (1122) AlN oriented regions. In contrast, a high

V/III ratio of 1043 leads to the formation of uniform semipolar (1122) AlN layers. Nevertheless, the formation of differently oriented AlN crystallites could not be suppressed completely. These randomly appearing crystallites still show a high vertical growth rate and lead to a deterioration of the surface morphology.

Estimation of the internal electric field inside (11-22) semipolar GaN/Al_{0.5}Ga_{0.5}N nanostructures and the radiative efficiency at low temperature

Abdelkarim Kahouli^{1,a}) and Nasser Kriouche¹
1 Université de Nice Sophia Antipolis, 06108 Nice Cedex 2, France

Journal of Applied Physics
Vol. 115, 193106 (2014);
<http://dx.doi.org/10.1063/1.4876446>

We report on time-integrated and resolved photoluminescence data on self-assembled semipolar (11-22) GaN nanostructures embedded in Al_{0.5}Ga_{0.5}N. It is confirmed that the internal electric field is reduced for semipolar (11-22) orientation. It is shown in particular that the value of the electric field is 450–500 kV/cm for this orientation. The photoluminescence decay time of excitons is used as a probe of the reduction of the internal electric field in the case of semipolar GaN nanostructures. The measured decays are not only controlled by radiative lifetimes, which depend on the fields inside GaN nanostructures, but also on the nonradiative escape of carriers through barriers. The correspondent decay time is found equal to 330 ps. By the study of the decay time as a function of the emission energy, we can determine the evolution of the internal quantum efficiency as a function of the nanostructures height (energy) and to have access to the nonradiative lifetime at low temperature.

OTHER

*Information selected by Agnès Trassoudaine
(Univ D'Auvergne)*

Present understanding of Eu luminescent centers in Eu-doped GaN grown by organometallic vapor phase epitaxy

Yasufumi Fujiwara¹ and Volkmar Dierolf²
1 Division of Materials and Manufacturing Science, Graduate School of Engineering, Osaka University, Suita, Osaka 565-0871, Japan
2 Physics Department, Lehigh University, Bethlehem, PA 18015, U.S.A.

Japanese Journal of Applied Physics
Vol. 53; 05FA13
<http://dx.doi.org/10.7567/JJAP.53.05FA13>

We have succeeded in growing Eu-doped GaN (GaN:Eu) layers with high crystalline quality by organometallic vapor phase epitaxy, and have demonstrated a low-voltage current-injected red emission from a light-emitting diode (LED) using the GaN:Eu layer with an applied voltage of as low as 3 V. By optimizing growth conditions and device structures, the light output power has increased steadily to up to sub-mW at an injected current of 20 mA. For further improvement of the output power, Eu luminescent centers have been spectroscopically investigated in GaN:Eu. A variety of Eu luminescent sites and a strongly site-dependent energy transfer process were clearly revealed. The energy-transfer efficiency was markedly enhanced by codoping of Mg with Eu. A proposed model for centers with high energy-transfer efficiencies is discussed in relation to the local structure.

Growth kinetics and mass transport mechanisms of GaN columns by selective area metal organic vapor phase epitaxy

Xue Wang^{1,a}), Jana Hartmann¹, Martin Mandl^{1,2},
Matin Sadat Mohajerani¹, Hergo-H. Wehmann¹,
Martin Strassburg² and Andreas Waag¹
1 Institute of Semiconductor Technology, Braunschweig University of Technology, Hans-Sommer-Straße 66, 38106 Braunschweig, Germany
2 Osram Opto Semiconductors GmbH, Leibnizstraße 4, 93055 Regensburg, Germany

Journal of Applied Physics
Vol. 115, 1664306 (2014);
<http://dx.doi.org/10.1063/1.4871782>

Three-dimensional GaN columns recently have attracted a lot of attention as the potential basis for core-shell light emitting diodes for future solid state lighting. In this study, the fundamental insights into growth kinetics and mass transport mechanisms of N-polar GaN columns during selective area metal organic vapor phase epitaxy on patterned SiO₂/sapphire templates are systematically investigated using various pitch of apertures, growth time, and silane flow. Species impingement fluxes on the top surface of columns J_{top} and on their sidewall J_{sw} , as well as, the diffusion flux from the substrate J_{sub} contribute to the growth of the GaN columns. The vertical and lateral growth rates devoted by J_{top} , J_{sw} and J_{sub} are estimated quantitatively. The diffusion length of species on the SiO₂ mask surface λ_{sub} as well as on the sidewall surfaces of the 3D columns λ_{sw} are determined. The influences of silane on the growth kinetics are discussed. A growth model is developed for this selective area metal organic vapor phase epitaxy processing.

Multi-bands photoconductive response in AlGaIn/GaN multiple quantum wells

G. Chen¹, X. Q. Wang^{1,2,a}, K. Fu³, X. Rong¹, H. Hashimoto⁴, B. S. Zhang³, F. J. Xu¹, N. Tang¹, A. Yoshikawa⁴, W. K. Ge⁵ and B. Shen^{1,2,b}

¹ State Key Laboratory of Artificial Microstructure and Mesoscopic Physics, School of Physics, Peking University, Beijing 100871, China

² Collaborative Innovation Center of Quantum Matter, Beijing, China

³ Suzhou Institute of Nano-Tech and Nano-Bionics, Chinese Academy of Sciences, Ruoshui Road 398, 215123 Suzhou, People's Republic of China

⁴ Center for SMART Green Innovation Research, Chiba University, 1-33 Yayoi-cho, Inage-ku, Chiba 263-8522, Japan

⁵ Department of Physics, Tsinghua University, Beijing 100871, China

Applied Physics Letters
Vol. 104, 172108 (2014);
<http://dx.doi.org/10.1063/1.4874982>

Based on the optical transitions among the quantum-confined electronic states in the

conduction band, we have fabricated multi-bands AlGaIn/GaN quantum well infrared photodetectors. Crack-free AlGaIn/GaN multiple quantum wells (MQWs) with atomically sharp interfaces have been achieved by inserting an AlN interlayer, which releases most of the tensile strain in the MQWs grown on the GaN underlayer. With significant reduction of dark current by using thick AlGaIn barriers, photoconductive responses are demonstrated due to intersubband transition in multiple regions with center wavelengths of 1.3, 2.3, and 4 μm , which shows potential applications on near infrared detection.

In situ X-ray diffraction monitoring of GaInN/GaN superlattice during organometallic vapor phase epitaxy growth

Taiji Yamamoto^a, Daisuke Iida^a, Yasunari Kondo^a, Mihoko Sowa^a, Shinya Umeda^a, Motoaki Iwaya^a, Tetsuya Takeuchi^a, Satoshi Kamiyama^a, Isamu Akasaki^{a, b}

^a Faculty of Science and Technology, Meijo University, Nagoya 468-8502, Japan

^b Akasaki Research Center, Nagoya University, Nagoya 464-8603, Japan

Journal of Crystal Growth
Volume 393, 1 May 2014, Pages 108–113
<http://dx.doi.org/10.1016/j.jcrysgro.2013.11.072>

We observed the growth of the Ga_{0.80}In_{0.20}N (2 nm)/GaN (3 nm) superlattice (SL) structure by in situ X-ray diffraction (XRD) monitoring. The satellite peaks from the -1st to the +1st order can be obtained from these in situ XRD spectrums. From the full width at half maximums (FWHMs) of the 0th and -1st satellite peaks as a function of the SL periods, we observed a clear trend in each FWHM. It was found that by analyzing this trend along with fluorescence microscopic and transmission electron microscopic analysis, an analysis of the In segregation and misfit dislocation are possible. Accordingly, if we employ in situ XRD under various growth conditions, the optimization of the growth conditions will become easier because it would be possible to determine the number of periods at which In segregation and misfit dislocation increases by only one growth procedure.

Optical properties of plasma-assisted molecular beam epitaxy grown InN/sapphire

Devki N. Talwara, Ying Chieh Liaob, Li Chyong Chenc, Kuei Hsien Chend, Zhe Chuan Fengb,

a Department of Physics, Indiana University of Pennsylvania, 975 Oakland Avenue, 56 Weyandt Hall, Indiana, PA 15705-1087, USA

b Institute of Photonics and Optoelectronics, Department of Electrical Engineering, and Center for Emerging Material and Advanced Devices, National Taiwan University, Taipei 106-17, Taiwan, ROC

c Center for Condensed Matter Sciences, National Taiwan University, Taipei 106-17, Taiwan, ROC

d Institute of Atomic and Molecular Sciences, Academia Sinica, Taipei 115, Taiwan, ROC

Optical Materials

<http://dx.doi.org/10.1016/j.optmat.2014.04.012>

The optical properties of as-grown InN/sapphire films prepared by plasma assisted molecular beam epitaxy (PA-MBE) are characterized by photoluminescence (PL), Raman scattering (RS) and infrared (IR) reflectance techniques. The PL measurements have consistently exhibited lower values of InN band gaps providing clear indications of electron concentration dependent peak energy shifts and widths. The phonon modes identified by RS are found to be in good agreement with the grazing inelastic X-ray scattering measurements and ab initio lattice dynamical calculations. An effective medium theory used to analyze IR reflectance spectra of InN/sapphire films has provided reasonable estimates of free charge carrier concentrations.

Raman characterization and stress analysis of AlN:Er³⁺ epilayers grown on sapphire and silicon substrates

T. Kallela, M. Dammaka, J. Wangb, W.M.

Jadwisienczakb

a Groupe des Matériaux Luminescents, Laboratoire de Physique Appliquées, Département de Physique, Faculté des Sciences de Sfax, Université de Sfax, Tunisia

b School of Electrical Engineering & Computer Science, Ohio University, OH 4570, USA

Materials Science and Engineering: B

<http://dx.doi.org/10.1016/j.mseb.2014.04.003>

Raman spectra and resulting stress analyses were performed for two sets of erbium implanted

aluminum nitride (AlN:Er³⁺) epilayers deposited by molecular-beam epitaxy (MBE) on (0 0 0 1) sapphire and (1 1 1) silicon substrates. The AlN:Er³⁺ epilayers were examined using Raman scattering at different temperatures revealing the presence of the allowed E₂(high) and A₁(LO) phonon modes. The E₂(high) mode linewidths reflect the best qualities of the implanted and thermally annealed epilayers grown on silicon substrates compared with those grown on sapphire substrates. It was observed that relatively tensile stress existed in AlN:Er³⁺ epilayer grown on sapphire in contrast to a compressive stress present in the AlN:Er³⁺ epilayer grown on silicon as indicated by the observed E₂(high) mode frequency shift and the broadening of the vibrational mode linewidth. The stress value was calculated. The temperature dependence of the E₂(high) frequency and linewidth for the AlN:Er³⁺ epilayer grown on sapphire were theoretically modeled.

Nucleation mechanism for epitaxial growth of GaN on patterned sapphire substrates

Shizhong Zhoua, Zhiting Lina, Haiyan Wang, Tian Qiaoa, Liyi Zhonga, Yunhao Lina, Wenliang Wang, Weijia Yanga, Guoqiang Lia, b,

a State Key Laboratory of Luminescent Materials and Devices, South China University of Technology, Guangzhou 510641, China

b Department of Electronic Materials, School of Materials Science and Engineering, South China University of Technology, Guangzhou 510640, China

Journal of Alloys and Compounds

<http://dx.doi.org/10.1016/j.jallcom.2014.05.035>

The nucleation behaviors of GaN epitaxially grown on the patterned sapphire substrate (PSS) at different growth stages are investigated in detail. It is demonstrated that, unlike the non-PSS case, the proposed patterns can induce the selective deposition of GaN grains at the stage of buffer layer growth. Afterwards, the uniformity in lateral growth is promoted at the subsequent stage of GaN islands growth, accompanied by the rearrangement of GaN grains at high temperature. Finally, the crystal quality of the films is improved evidently at the stage of GaN recovery-mode growth. As confirmed by Raman spectroscopy and microscopy measurements, stress relaxation and

lateral overgrowth acceleration are revealed to show good prospects in the application of PSS. The underlying mechanisms for both GaN nucleation and lateral overgrowth acceleration on PSS are elucidated carefully.

The role of donor-acceptor pairs in the excitation of Eu-ions in GaN:Eu epitaxial layers

B. Mitchell¹, J. Poplawsky^{1,a}), D. Lee², A. Koizumi², Y. Fujiwara² and V. Dierolf¹

¹ Lehigh University, 16 Memorial Dr. E, Bethlehem, Pennsylvania 18015, USA

² Osaka University, 2-1 Yamadaoka, Suita, Osaka 565-0871, Japan

Journal of Applied Physics

Vol. 115, 204501 (2014)

<http://dx.doi.org/10.1063/1.4879253>

The nature of Eu incorporation and resulting luminescence efficiency in GaN has been extensively investigated. By performing a comparative study on GaN:Eu samples grown under a variety of controlled conditions, and using a variety of experimental techniques, the configuration of the majority site has been concluded to contain a nitrogen vacancy (VN). The nitrogen vacancy can appear in two symmetries, which has a profound impact on the luminescence and magnetic properties of the sample. The structure of the minority site has also been identified. We propose that, for both sites, the excitation efficiency of the red Eu emission is improved by the presence of donor-acceptor pairs in the close vicinity of the Eu.

PRESS RELEASE

Technical and economic information selected by Knowmade

OPTOELECTRONICS

Epistar extends LED collaborative development program and IP licensing agreement with Intermolecular

Semiconductor Today

LED chipmaker Epistar Corp of Hsinchu, Taiwan and Intermolecular Inc of San Jose, CA, USA have signed a multi-year extension of their existing collaborative development program (CDP) and royalty-bearing IP licensing agreement of April 2013 to increase the efficiency and reduce the cost of Epistar's LEDs.

Under the terms of the agreement, the firms' engineers will continue to work together to leverage Intermolecular's proprietary high-productivity combinatorial (HPC) technology platform to accelerate development and manufacturing qualification of novel materials and processes for advanced LED products.

Founded in 2004, Intermolecular says it has pioneered a proprietary approach to accelerate research and development, innovation, and time-to-market for the semiconductor and clean energy industries. The approach consists of its HPC platform, application-specific workflows and its multi-disciplinary team. Through paid collaborative development programs with customers, Intermolecular develops proprietary technology and intellectual property for its customers focused on advanced materials, processes, integration and device architectures. Intermolecular's mission is to improve R&D efficiency in the semiconductor and clean energy industries through collaborations that use its HPC platform, which allows R&D experimentation to be performed at speeds up to 100 times faster than traditional methods.

"Epistar is leveraging Intermolecular's HPC methodology and technology in order to accelerate R&D experimentation as we bring more advanced, higher-performing LED devices to market," says Carson Hsieh, Epistar's vice president of R&D. "Our CDP with Intermolecular

helped to significantly increase the performance of one of our LED products during development, and we are now in the process of implementing that technology in production. In the coming years we expect our continuing relationship with Intermolecular to support further advancements in our technology roadmap," he adds.

"Increasing LED efficiency is the key to reducing LED system cost and enabling widespread adoption of more innovative lighting products," says Sandeep Nijhawan, senior VP & general manager, Clean Energy Group at Intermolecular. The multi-year agreement extension will support Epistar's product innovation strategy through accelerated materials development and LED device integration, he adds.

[Read more](#)

Anvil awarded TSB grant to grow high-quality GaN on 3C-SiC on large-diameter silicon

Semiconductor Today

Anvil Semiconductors Ltd of Coventry, UK has been awarded a grant by the UK's Technology Strategy Board (TSB) to evaluate the feasibility of using its unique stress relief technology to enable the production of low-cost, high-brightness LEDs on large-diameter silicon substrates.

Anvil was spun off in August 2010 from the University of Warwick's School of Engineering by its technology commercialization subsidiary Warwick Ventures Ltd in order to exploit patented developments in SiC power semiconductor technology. Anvil says that its approach to SiC switches should cost no more than their silicon counterparts. This involves growing a thin layer of cubic SiC (3C-SiC) on silicon substrates sufficient to fabricate active power devices. In addition to the fundamental crystal growth expertise, Anvil has IP relating to resolving the problem of the stress that inevitably arises when growing SiC on Si (which to date has prevented widespread adoption of the technology). The IP has been proven on 100mm-diameter silicon wafers and can be migrated onto larger wafer diameters without modification.

Fabricating gallium nitride (GaN)-based LEDs on large-diameter silicon wafers is recognized as a key path to reducing the cost of lighting systems and displays. However, existing techniques used to manage the large mismatches in lattice parameter and thermal coefficient of expansion between silicon and GaN are complex and costly and have struggled to deliver materials suitable for high-efficiency devices, says Anvil. However, with the growth of GaN-based LED structures on SiC already well established, high-quality 3C-SiC on silicon produced using Anvil's proprietary stress relief technology could provide an alternative that can be readily migrated onto 150mm diameter substrates and beyond, the firm reckons.

The grant will fund work to produce and characterize typical GaN-based epilayers on Anvil's 3C-SiC on silicon wafers. With Anvil's process able to produce high-quality 3C-SiC surfaces with orientation close to (100), the project will also explore the technology's potential for producing the elusive cubic and, importantly, non-polar form of GaN. If successful, this could pave the way for further device benefits including improved LED efficiencies and lower-power-consumption displays, it is foreseen.

"We're delighted to have been given this opportunity to explore the potential for Anvil's technology in another exciting market," comments CEO Jill Shaw. "If we're successful, we will be looking for partners to help us take it forward."

[Read more](#)

Alcom to distribute Plessey's GaN-on-Si LEDs in Benelux

Semiconductor Today

Plessey Semiconductors Ltd of Plymouth, UK has entered into a distribution agreement with Netherlands-based electronics distributor Alcom Electronics B.V. to expand its European network with coverage in the Benelux market for its gallium nitride on silicon (GaN-on-Si) LED products.

"The innovative Plessey LED solution fits very well within Alcom's market approach," says Alcom's managing director Marcel den Bak. "We are offering the newest technology in the respective markets we are active in, making sure that our customers can be more competitive in their end

applications. Plessey, being an early adaptor of GaN-on-Si LED technology, will bring Alcom and its customers an extremely competitive, high-quality light source," he believes.

"Plessey is very pleased to work with a distributor that has been focusing on the solid-state lighting market for a considerable number of years," comments Plessey's regional sales director David Owen. "Alcom has a dedicated team working in the lighting segment and therefore considerable knowledge of the growing Benelux lighting industry and customer base, which will accelerate the time to market for Plessey GaN-on-Si LEDs in this region."

[Read more](#)

Osram opens LED assembly plant in China

Semiconductor Today

In a further move to strengthen its position in the LED market, Germany's Osram has officially opened its LED assembly plant in Wuxi, China. The factory has a floor area of about 100,000m² and will employ as many as 2100 staff by 2017. Osram is investing a low three-digit-million euro amount to set up the plant. "With this step, we are not only expanding our fully loaded backend LED capacities but also boosting our presence in the world's largest single lighting market," says Osram Licht AG's CEO Wolfgang Dehen. "Asia, and particularly China, are key growth drivers for the global lighting and therefore the LED industry," he adds.



Product testing at Osram's new LED assembly plant in Wuxi. Picture: Product testing at Osram's new LED assembly plant in Wuxi.

China accounts for more than 20% of the world's lighting market and has recorded fast growth over the past few years, particularly in the uptake of LED lighting technologies. The country's total general illumination market is expected to rise from about €15bn in 2013 to €23bn by 2019, while the market share of semiconductor-based products such as LEDs is forecast to surge from only 29% to more than 60%.

With the new LED assembly in Wuxi, Osram says that it will be in a better position to address that growth. The contracts for the plant's location were signed in May 2012, followed by groundbreaking that August. "Osram's new LED assembly plant will play a key role in forging Wuxi's LED industry value chain, and we believe operation of the plant will help Wuxi to become one of the foremost optoelectronic semiconductor bases in China, and even Asia," stated Wang Quan, deputy secretary of Wuxi Party Committee and mayor of Wuxi.

Planned and run by the Osram Opto Semiconductors business unit, the factory is the firm's second back-end site where LED chips are assembled them into packages, adding to the existing site in Penang, Malaysia. Osram Opto Semiconductors also operates front-end chip production sites at its headquarters in Regensburg, Germany, as well as in Penang. The Wuxi plant will be capable of an annual output of up to several billion LEDs.

"Our business has always been a global business and, taking into account the size and growth prospects of the Chinese market, Wuxi is a perfect fit for our manufacturing footprint," reckons Osram Opto Semiconductors' CEO Aldo Kamper. "The plant will help us to further develop our professional know-how and understanding of our customers' products."

[Read more](#)

Soraa & the Rendering of Whites

All LED Lighting

There has been big pickup of the story we covered in February: the Penn State study that Soraa sponsored, demonstrating that blue-pumped LED light does not activate the optical brightening agents (OBAs) present in pretty much any product that the manufacturers want to appear whiter

than white. We had introduced the topic of OBAs the previous September.

But in the more mainstream tech coverage, Soraa may not be getting its money's worth from the research sponsorship. Soraa's point, of course, is that its violet-pumped LEDs do activate OBAs. In other words, ordinary LEDs cause a problem that heretofore has not been widely discussed, and Soraa has the solution.

Essentially none of the widespread coverage I have seen mentions Soraa's solution. It's mostly just decrying how yellow our shirts will look.

[Read more](#)

Substrates are shaping the LED Front-End industry, announces Yole Développement

I-micronews

Yole Développement releases this week its report, LED Front-End Manufacturing Trends. "New LED substrate is one of the key topics impacting the LED Front-End industry", explains Pars Mukish, Technology & Market Analyst at Yole Développement (Yole). "Substrates are clearly shaping this industry with the start of the use of Silicon and bulk GaN as a potential replacement of sapphire", he adds. Under this report, Yole's analyst provide a better understanding of the current process flow, process steps and technological trends in LED Front-End manufacturing. Pars Mukish details the importance of cost reduction in this area as well. Moreover, he evaluates emerging substrates and related technologies including GaN-on-GaN LEDs and GaN-on-Si LEDs.

Under this report, Yole identified three main impacts:

- Increased demand for larger size sapphire wafers with big players, such as LG, Sharp or Osram moving to 6" wafers and Taiwanese players moving to 4" wafers.
- Increased demand for PSS that has now become mainstream in the industry (87% share as of Q1-2014), even if some questions remain concerning key patent holders' strategies.
- Development of GaN-on-Si and GaN-on-GaN LEDs with both technologies having begun mass production in some companies (such as Soraa for GaN, or Toshiba for Si). "However, market penetration of these alternative

substrates will be secondary to future improvements in terms of performance and cost”, says Pars Mukish. Otherwise, GaN-on-Si and GaN-on-GaN LEDs will not be able to fully compete with sapphire-based LEDs.



The impact of the sapphire industry on the LED industry is likely to become bigger in the future because of the recent partnership between GTAT and Apple (Q4-2013) to set up a large sapphire manufacturing plant (\$1 billion). The plant, having a rough capacity of 2 times the current qualified sapphire capacity, could totally modify the structure and evolution of the sapphire and LED industries in the next few years.

Yole Développement’s report presents all recent technological trends of LED Front-End manufacturing, detailing evolutions at substrate, epitaxy, lithography, plasma etching and deposition, PVD and testing levels.

[Read more](#)

How to decrease the LED Front-End cost by 15% every year?

I-micronews

In parallel to implementing the semiconductor practice in Front-End manufacturing, these are the substrates that are shaping the innovation of LED Front-End industry!

The overall Front-End manufacturing trends for LED manufacturing are following the same path: decrease manufacturing costs, increase yield to improve binning, extract more light per mm² and per watt injected into the die... So all Front-End equipment makers are now developing or introducing new equipment (including MOCVD reactors) in order to be involved in the new

investment wave that will happen from 2014 to 2017 as the new Yole Développement report “LED Front-End manufacturing trends” is highlighting.

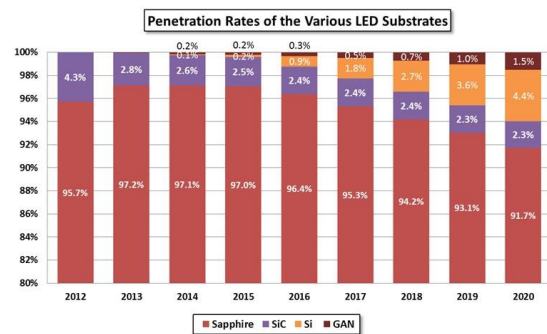

What is extremely surprising is that LED manufacturing still uses methods and practices that would be considered outdated in most semiconductor industries (e.g.: manual wafer handling, with operators moving wafers with tweezers in (not so) clean rooms...). However, emergence of LED “giants” (such as Cree, Osram, Lumileds, Samsung or LG) have facilitated and speed up adoption of manufacturing paradigms from the IC industry to reduce overall manufacturing cost and increase products quality. The new mottos are moving from batch processing to single wafer, use automation, cluster tools, full cassette to cassette (...), deploy statistical process control, defect management (...), work on reduction of SKU and enterprise Management Systems (EMS)... All brand new topics not seen before in the LED industry.

[Read more](#)

ELECTRONICS

EPC launches 11-part educational video podcast series on GaN power transistors

Semiconductor Today

Efficient Power Conversion Corp (EPC) of El Segundo, CA, USA, which makes enhancement-mode gallium nitride on silicon (eGaN) power field-effect transistors (FETs) for power management applications, has created and posted on line an 11-part educational video podcast series designed to provide power system design engineers with a technical foundation and application-focused toolset on how to design

more efficient power conversion systems using GaN-based transistors.

[Read more](#)

MACOM launches 55W GaN-on-SiC pulsed power transistor with 55% PAE up to 3.5GHz

Semiconductor Today

M/A-COM Technology Solutions Inc of Lowell, MA, USA (which makes semiconductors, components and subassemblies for analog, RF, microwave and millimeter-wave applications) has launched a gallium nitride on silicon carbide (GaN-on-SiC) HEMT pulsed power transistor for civilian and military radar pulsed applications.

The MAGX-000035-045000 is a gold-metalized unmatched GaN-on-SiC RF power transistor optimized for high-performance RF applications such as L-band and S-band radar. Operating from a supply voltage of 50V, it provides typical peak output power of 55W with 11.3dB of power gain and 55% power-added efficiency (PAE). Load mismatch stability (VSWR-S) is 5:1 and load mismatch tolerance (VSWR-T) is 10:1. The device is assembled in a small 20.3mm x 5.8mm Cu/Mo/Cu flanged ceramic package, enabling higher power and efficiency for demanding applications.

Operating in the DC-3500 MHz frequency range, the MAGX-000035-045000 is a highly robust transistor with high voltage breakdown and a mean time to failure (MTTF) of 600 years. "The new GaN power transistor offers a versatile and high-performance solution for pulsed driver and power applications over a broad frequency range," says product manager Paul Beasley. Samples are available from stock.

[Read more](#)

MACOM adds 17 GaN-on-Si RF power transistors and amplifiers to its portfolio

Semiconductor Today

M/A-COM Technology Solutions Inc of Lowell, MA, USA (which makes semiconductors, components and subassemblies for analog, RF, microwave and millimeter-wave applications) has announced the availability and full technical support for 17 high-performance gallium nitride on silicon (GaN-on-Si) RF power transistors and amplifiers recently added to its product portfolio as a result of its acquisition in February of Nitronex LLC of Durham,

NC, USA (a designer and manufacturer of GaN-on-Si-based RF power devices).

GaN offers high bandwidth and efficiency for RF applications, including defense communications, land mobile radio, avionics, wireless infrastructure, ISM (industrial, scientific & medical) applications and VHF/UHF/L-band. With the addition of these GaN-based RF solutions, MACOM reckons it now has the broadest family of GaN technology in the industry, including fundamental and innovative GaN-on-Si epitaxial and pseudo-epitaxial semiconductor process technology and materials.

"Broadening our portfolio of GaN-on-Si and GaN-on-SiC technologies enables our customers greater flexibility in selecting the best solution to solve their RF and microwave design challenges," says senior VP & general manager Suja Ramnath. "This, combined with MACOM's decades of expertise in large-scale RF semiconductor technology, along with surety of supply and deep technical support, is enabling us to accelerate mainstream GaN adoption."

The latest GaN components are now in stock and available for immediate delivery from MACOM and its distribution partners.

[Read more](#)

Hittite acquires assets of Keragis

Semiconductor Today

Hittite Microwave Corp of Chelmsford, MA, USA (which designs and supplies analog, digital and mixed-signal RF, microwave and millimeter-wave ICs, modules and subsystems as well as instrumentation) has now acquired the assets of Keragis Corp of San Diego, CA, following a definitive agreement announced in March.

Founded in 1993 and privately owned by Robert and Maria Rector, Keragis provides high-power, wideband amplifier modules (operating at 0.5-32GHz) that utilize both gallium arsenide (GaAs) and gallium nitride (GaN). The high-performance military-grade and rugged commercial products have applications in RF and microwave systems, including radar subsystems, rack-mounted instruments, phased arrays and tow decoys.

The acquisition expands Hittite's power amplifier portfolio, combining Hittite's capabilities in designing and manufacturing ICs, modules and

subsystems with Keragis' patented wideband high-power amplifier module products.

Hittite says that, as a result of the acquisition, it will initially offer 10 military-grade and rugged commercial amplifier products featuring broadband high power, compact size, and high efficiency.

[Read more](#)

GaN-on-Diamond: The Next GaN

Microwave Journal

Engineers in the defense community have long sought to replace the bulky and heavy traveling wave tubes (TWT) used in high power systems such as radar, communications satellite and electronic warfare (EW) with compact, lightweight, cheaper and more efficient semiconductor components. Semiconductors also enable system level features like phased array radars. More than any other semiconductor material, GaN exhibits intrinsic properties that make it as promising as a TWT replacement; its wide band gap enables high voltage operation and high power added efficiencies (PAE). However, thermal limitations have so far impeded the industry's progress toward GaN's optimal performance as GaN's RF power is increased.

[Read more](#)

GaN Systems presenting lateral transistors for HEVs; launching high-current devices

Semiconductor Today

GaN Systems Inc of Ottawa, Ontario, Canada, a fabless developer of gallium nitride (GaN)-based power switching semiconductors for power conversion and control applications, is exhibiting in booth 9-523 at PCIM (Power Conversion Intelligent Motion) Europe 2014 in Nuremberg, Germany (20–22 May).

PCIM focuses on power electronics and its applications in intelligent motion, renewable energy and energy management, and GaN Systems has selected the event to reveal its latest developments and make two announcements on its gallium nitride power semiconductors.

At the PCIM conference, Larry Spaziani is presenting the paper 'Lateral GaN Transistors – A Replacement for IGBT devices in Automotive Applications' (written by chief technical officer John Roberts) explaining the performance

improvements that GaN devices achieve in drive train power requirements for hybrid and electric vehicles (HEVs). Worldwide, several groups of researchers are undertaking work on replacing silicon insulated-gate bipolar transistors (IGBTs) in these applications. Spaziani is presenting results achieved by GaN Systems' devices, which are based on the firm's unique Island Technology intellectual property (IP). The presentation will include a comparison between the company's products and competing offerings.

Also at PCIM, GaN Systems is making two major announcements: the forthcoming commercial availability of its GaN high-current devices and 100V process qualification.

[Read more](#)

Transphorm obtains exclusive licensing rights to Furukawa's GaN patent portfolio

Semiconductor Today

Transphorm Inc of Goleta, near Santa Barbara, CA, USA (which designs and delivers power conversion devices and modules) has obtained a sole worldwide license to Furukawa Electric Co Ltd's extensive gallium nitride (GaN) power device portfolio, which includes about 40 US issued patents and 110 Japanese issued patents. Transphorm also has certain rights to sublicense these patents.

The licensed family of patents encompasses various aspects of GaN power device manufacturing, materials and circuits, including key patents for GaN-on-silicon epitaxial growth technology. As part of the agreement, Furukawa Electric also made an equity investment in Transphorm. The deal brings Transphorm's total GaN IP portfolio to over 300 US patents/applications and over 650 worldwide patents/applications, including a combination of internally developed, acquired and licensed patents.

Transphorm says that, over the last several years, GaN semiconductors have emerged as a technology enabler for the next wave of compact and energy-efficient power conversion systems, ranging from ultra-small adapters, high-power-density PCs, server & telecom power supplies, to highly efficient PV inverters and motion control systems.

Transphorm has established a power conversion platform, involving introducing what was claimed to be the first 600V GaN HEMT products after successfully passing JEDEC qualification. Most recently it has demonstrated 100 million hours lifetime using high-voltage accelerated testing (again, a first for a GaN power device, the firm says). "As GaN power devices are now poised for rapid market penetration, a strong intellectual property position is essential to growing the GaN business," notes Roger Borovoy, Transphorm's IP counsel from Fish & Richardson. "The Furukawa license, combined with a very significant internal GaN portfolio, unquestionably makes Transphorm the key player," he adds.

"Furukawa Electric has conducted original GaN research starting from the 1990s and amassed a strong patent portfolio in GaN power devices and materials," says Takahide Kimura, corporate senior VP, New Business Development, at Furukawa Electric. "As we sought to unlock the value of this portfolio, as well as to secure a supply of GaN products for our own applications, Transphorm was an ideal choice. Additionally, Furukawa Electric is also willing to have further technical collaboration with Transphorm, as a strategic partner, beyond this license and investment," he adds.

"Furukawa Electric has made a significant equity investment and obtained a minority equity stake in Transphorm," says Transphorm's CEO Fumihide Esaka. "We are pleased to announce this strong partnership with a global leader like Furukawa Electric."

[Read more](#)

Transphorm appoints HY-LINE as Central Europe distributor of 600V GaN HEMTs

Semiconductor Today

Transphorm Inc of Goleta, near Santa Barbara, CA, USA, which designs and provides gallium nitride (GaN)-based power conversion devices and modules for power supplies and adapters, motor drives, solar inverters and electric vehicles, has completed a distribution agreement with HY-LINE Power Components GmbH of Munich, Germany to stock and distribute its family of 600V GaN high-electron-mobility transistors (HEMTs) in Central Europe.

HY-LINE's technical expertise will support the growing demand for JEDEC-qualified 600V GaN products that have now grown to the level requiring an expanding sales channel to respond to opportunities, specifically in Germany, Switzerland and Austria.

"HY-LINE is specialized in offering cutting-edge, energy-saving technology. Transphorm's technical leadership in the emerging GaN technology including, to-date, being able to offer production volume of 600V GaN-on-silicon HEMTs, has moved GaN from potential to practical use in high-efficiency power conversion systems," comments HY-Lines' CEO Jochen Krause. "This distribution agreement with Transphorm will allow us to offer these unique products to customers in Central Europe who require the power savings that only GaN can achieve," he adds.

"We selected HY-LINE Power Components based upon their technical expertise and ability to both create and support demand in the rapidly growing segment of the power conversion market," says Transphorm's VP of sales Bret Daniels. "With the completion of qualification last year, Transphorm's GaN devices have moved from advanced engineering research into product design and production, which makes this the right time to expand into distribution."

Transphorm says that, based on its proprietary EZ-GaN platform, its power conversion solutions reduce power system size, increase energy density and deliver high efficiencies across the grid.

[Read more](#)

Cree launches highest-power and -frequency plastic-packaged GaN transistors for low-cost radar and datalinks

Semiconductor Today

Cree Inc of Durham, NC, USA has introduced what it claims are the industry's highest-power continuous wave (CW) RF gallium nitride (GaN) high-electron-mobility transistors (HEMTs) packaged in a dual-flat no-leads (DFN) format.

Targeted at the cost-sensitive sub-100W commercial radar and data-link amplifier market segments, the new 6- and 25-watt DFN transistors effectively obsolete the use of inefficient gallium arsenide (GaAs) transistors in C- and X-band frequencies, claims Cree, and also enable the practical replacement of short-life tube-based

technology for commercial radar applications such as weather, marine and surveillance.

Based on Cree's proven 40V, 0.25µm-gate-length high-frequency process, Cree reckons that its GaN DFN transistors deliver twice the saturated output power (PSAT) efficiency and transistor gain of GaAs IMFETs (internally matched field-effect transistors) in a package size that is nearly 20 times smaller at comparable power levels and frequencies. In high-capacity microwave data links used in enterprise, point-to-point and airborne communication networks, the new transistors extend the communication range while delivering twice the linear efficiency of GaAs-based amplifiers. This higher efficiency gives RF designers the flexibility needed to reduce amplifier size and weight, creating savings in operating and total lifecycle costs, says Cree.

"For years, commercial microwave radar transmitters have been plagued with the compromised field life of tube-based amplifiers that carry significant maintenance costs," says Tom Dekker, Cree's director of RF sales & marketing. "Historically, high-capacity data links were limited to the use of inefficient GaAs IMFETs," he adds. "By delivering superior efficiency and power capabilities at an affordable price, our new GaN DFN transistors enable for the first time the replacement of these legacy technologies in lower-power, cost-sensitive commercial systems."

The new DFN devices can also make act as drivers for Cree's CGHV96100 and CGHV96050F2 fully matched FETs for X-band frequencies, enabling the output- and drive-stage transistors to operate from the same voltage rail. This allows convenient, regulated power distribution to economize board space compared with a mixed-voltage transistor line up.

Samples and reference designs for C- and X-band are available now utilizing the CGHV1F006S (6W) and CGHV1F025S (25W) GaN DFN transistors. Large-signal models are also available for Agilent's ADS and AWR Microwave Office simulators.

[Read more](#)

CREE vertical integration will help staying ahead of the GaN RF competition

I-micronews

Yole Développement interviewed Ray Pengelly, Strategic Business Development Manager, Cree RF Components, that recently announced commercialisation of the highest power and frequency plastic packaged GaN transistors for low cost radar and datalinks.

According to Yole Développement data (detailed in the new RF GaN Technology & Market Analysis report), RF GaN devices continue to challenge silicon's dominant position. If the GaN-on-Si could be implemented in the 2-5 years, a more optimistic penetration rate- higher than 20% - could be envisaged. In the nominal forecast, RF GaN could reach more than 18% of the overall RF device market by 2020 (i.e. a 9% CAGR from 2013 to 2020). CREE is targeting RF GaN market mainly based on SiC substrates ; let's discover how it will happen...

Yole Développement: Overall, how does CREE envision the future of wireless telecom in both civilian and defense applications ?

Ray Pengelly: We see the future of wireless telecom to be very healthy both in civilian and defense applications. Higher data rates, carrier aggregation, super-Wi-Fi (802.11ac), interactive applications such as 802.11p, battlefield comms. via "cellular" or satellite services will all contribute to the market.

YD: GaN tends to displace incumbent GaAs HEMT and Si LDMOS in high power RF apps. Is it a simple substitution or does it need a full redesign of the RF chain ?

RP: The answer depends on application but generally the reasons for changing from GaAs and/or Si to GaN are higher instantaneous bandwidths, wider channel bandwidths, higher gain/efficiency, smaller size and weight and lower power consumption. This really translates to redesign of the RF chain given a different voltage rail may also be required in the case of 50V GaN.

YD: What are the main technical and non-technical drivers using Wide-BandGap devices in RF apps ?

RP: The technical drivers depend on application but can include higher power density, higher allowable operating temperatures compared to GaAs or Si (by > 50 deg C), higher gain per device, higher watts/sq.mm both for discretés and MMICs, smaller overall size, higher efficiencies leading to lower power consumption and operating costs, superior reliability.

YD: Which applications fit best with GaN today ? and tomorrow ?

RP: Today, the most popular applications for GaN are in wide-band PA's covering between octave and decade bandwidths for test instrumentation, military communications, CATV, etc.. GaN is also being heavily used in AESA's over a range of frequencies from L thru' X-band. GaN is being used in switch mode PA's, Class F and Class J amplifiers for telecom applications associated with a range of high efficiency techniques the most popular being Doherty and Envelope Tracking. As gate lengths shrink GaN will be used more tomorrow in applications through Ka band and higher including SATCOMs, back-haul and automotive radars.

YD: Is the extra-cost of GaN balanced by real and proven added-values at system or module level ?

RP: Because GaN (at least from Cree's perspective) is being used extensively now for telecom applications (mainly LTE), shipments of transistors has now reached millions per year leading to very significant cost reductions in that market-place. This has a knock-on effect in other applications. GaN costs are also dependent on the required specifications of the application particularly for state-of-the-art systems so in those cases the "extra-cost" of GaN is worthwhile to achieve metrics which would be very difficult or impossible to do using alternative approaches.

YD: CREE recently introduces highest power and frequency plastic packaged GaN HEMT for low cost radar and datalinks. Can plastic packages cover all high power RF apps ?

RP: Plastic packages are good for low CW powers up to 45 watts or higher power pulsed (low average power) applications. Where plastic packaging (at least today) has issues is for very high power CW operation. The need for Plastic

packaging is usually driven by the need to lower overall product cost just as in the case of Si LDMOS. Plastic packaging does not compromise performance (other than that noted earlier) and can be used up to mm-wave frequencies.

YD: How do you envision recent Nitronex acquisition by MACOM? Any threat with GaN-on-Si vs. GaN-on-SiC ? What are the value-proposition of both technologies?

RP: The Nitronex acquisition by MACOM should provide needed funding to continue the development of GaN-on-Si. Historically, GaN-on-Si use has been primarily confined to fairly low power, lower frequency applications (e.g. Mil COMMs, CATV, etc). Silicon substrate thermal resistance and RF loss have limited its use in higher power and higher frequency applications. Given that GaN-on-SiC is establishing a rapidly growing installed base and its price has dropped so rapidly with the prospect of future price reductions with the eventual migration to 6-in SiC substrates, there will likely not be great incentive to use GaN-on-Si for higher power applications but it is likely the technology will continue to improve for niche segments.

YD: RF industry consolidation leads to bigger players like TriQuint + RFMD. Both had strong involvement in GaN RF developments before merging. How CREE will stay ahead of the competition in such a new playground?

RP: We view consolidation as very healthy for the industry. Cree is a large, vertically integrated company that consumes and sells a large number of SiC substrates and GaN epitaxy. We also have a large and growing SiC Power business that runs on the same line as our GaN RF products. Our RF business is able to leverage this corporate scale to be very competitive in the industry.

[Read more](#)

GaN Systems launches 650V normally-off GaN transistor family

Semiconductor Today

GaN Systems Inc of Ottawa, Ontario, Canada, a fabless developer of gallium nitride (GaN)-based power switching semiconductors for power conversion and control applications, has announced five new normally-off 650V GaN transistors optimized for high-speed system design. The GS66502P, GS66504P, GS66506P and GS66508P are, respectively, 8.5A/165mΩ, 17A/82mΩ, 25A/55mΩ and 34A/41mΩ parts, while the GS43106L is a 30A/60mΩ cascode.

The new 650V enhancement-mode parts feature a reverse current capability, zero reverse recovery charge and source-sense for optimal high-speed design. RoHS compliant, the devices are delivered in GaN Systems' near-chipscale embedded GaNPX package, which eliminates wire bonds, thereby minimizing inductance. This package also optimizes thermal performance and is extremely compact, says GaN Systems.

"With these new 650V parts as well as our recently announced 100V family, GaN Systems offers a very wide range of parts which are available for are sampling now," says president Girvan Patterson. Applications include high-speed DC-DC converters, resonant converters, AC motor drives, inverters, battery chargers, and switched mode power supplies."

[Read more](#)

GaN Systems' director of US business development elected to board of Power Electronics Industry Collaborative

Semiconductor Today

GaN Systems Inc of Ottawa, Ontario, Canada, a fabless developer of gallium nitride (GaN)-based power switching semiconductors for power conversion and control applications, says that Julian Styles, its director of business development USA, has been elected to the board of the Power Electronics Industry Collaborative (PEIC), the US industry-driven, membership-based consortium of suppliers, OEMs, research companies and other stakeholders working to accelerate the development and growth of power electronics in the USA. PEIC's aim is to increase investment in manufacturing capabilities and advance innovation in power electronics in the USA as

energy efficiency becomes increasingly important globally.

GaN Systems has developed a range of gallium nitride power switching products based on its proprietary Island Technology. The firm says that its devices can overcome the limitations of traditional silicon semiconductors, offering far greater efficiency in power conversion applications such as solar, wind, smart-grid, electric and hybrid vehicles and power supply applications. GaN Systems recently announced that its products will be widely commercially available this year.

"Innovative semiconductor companies like GaN Systems succeed best when they are part of a thriving power electronics ecosystem," believes Styles. "We are very impressed with PEIC's efforts to build and strengthen this ecosystem in the USA."

[Read more](#)

OTHER

GaN-on-Silicon devices is now entering the volume production for power devices and LED

I-micronews

Yole Développement interviewed David Williams, VP of Business Development at Translucent, a provider of GaN on Si epiwafer, on the business, technology trends and IP...

According to Yole Développement data (available in the report "GaN-on-Si Substrate Technology and Market for LED and Power Electronics"), GaN on Si epiwafer will be a market of around \$ 320 million in 2020 for the production of LED and power devices. Just counting the open market (\$133 million in 2020) the forecast CAGR through the period 2015 to 2020 is ~42% - which we agree will see strong growth in the latter part of the decade. Translucent is targeting this market; let's discover how it will happen...

Yole Développement: Can you give us an overview of Translucent?

David Williams: Translucent Inc. was founded as an advanced semiconductor materials company in 2001. Australian listed public company Silex Systems Limited (ASX:SLX) (OTCQX:SILXY) has been the sole investor in Translucent, which remains a subsidiary of Silex. The initial market

focus was the rapidly growing photonics/optical communications market, but this evaporated in the early 2000's after the telecoms downturn. Translucent quickly adapted and continued to develop its core materials technology with a shift in focus to other markets. Today, Translucent has two product offerings, mainly GaN-on-Si epiwafers and Ge-on-Si epiwafers.

These products are aimed at the Power Electronics and Concentrating Photovoltaics (CPV) markets, respectively.

YD: What is original in Translucent activities related to GaN on Si?

DW: Translucent's GaN-on-Si epiwafers are more precisely described as an advanced GaN-on-insulator product. The intermediary between the GaN and the silicon is a single crystal Rare Earth Oxide (REO) transition layer. The composition of the REO is chosen so that it is lattice matched to the silicon on its lower surface. The upper surface is engineered to be compatible with standard GaN MOCVD processes. As well as providing a transition layer from the silicon wafer to the GaN epi layer, the REO provides functionality that may be useful to III-N device manufacturers: just to name a few, like bow control, chemical and electrical barrier between the substrate and the GaN device layer.

YD: What is Translucent's business model and what is the commercialization status?

DW: Translucent is offering epiwafers to its customers. Translucent is presently developing its manufacturing process and production equipment in preparation for full commercialization. Demonstration of 2DEG HEMT structures on GaN deposited on the single crystal REO layer (in turn deposited on silicon wafer) has been completed and validated. REO-on-silicon production has recently been scaled to 200mm, whilst MOCVD deposition of GaN-on-REO is currently being optimized on our 150mm platform. The final step on the path to commercialization - transferring the GaN-on-REO process to 200mm is expected to be completed in the near future. Additional potential commercial applications beyond power electronics (eg. advanced LED/photonics substrates) will be investigated in the future.

YD: How do you see the growth of GaN epiwafer?

DW: The more attractive market for Translucent is power devices. LED has a lower value at processed wafer level and has difficulties to support the added value and cost structure of engineered wafers.

For power devices, this is totally different: based on Yole Développement data (available in the report "GaN on Si technology and market" report) GaN on Si epiwafer will be a market worth around M\$ 320 million in 2020 for the production of LED and power devices. Looking at just the open market component (around \$133 million by 2020), the CAGR from 2015 to 2020 is approximately 42%, which obviously indicates a very strong growth trend in the latter half of this decade and beyond. We at Translucent agree with this forecast – there is already very strong industry interest building for GaN-on-silicon epiwafer products.

YD: What has been Translucent's patent strategy up to now for GaN on Si technology?

DW: Importantly, in addition to the noted technical and performance benefits, we believe that Translucent's unique REO-based approach underpins a very strong IP position. The company's extensive patent portfolio provides comprehensive protection of the silicon/REO and the REO/GaN interface material technology. We believe this has considerable merit in a climate of very public patent disputes in the GaN-on-silicon field.

At the beginning, we patented REO buffer layers. We believe that Translucent's unique REO-based approach underpins a very strong IP position. We then extend our patent portfolio to silicon/REO, the REO/GaN interface and GaN nucleation layer. We are presently developing 2DEG HEMT structures for power application. Since REO is also a high-k dielectric (relative permittivity 12 to 15), we can use it at the top of a device structure as for in-situ passivation and the gate dielectric. We have been active in protecting the materials-based IP. We now have comprehensive protection of the entire GaN-on-si epiwafer using the REO technology.

Transistor IP (see picture below):

1. Interface between silicon and REO material. - pre-straining silicon, bow engineering
2. Bulk Oxide – breakdown voltage, bow engineering
3. Oxide termination – MOCVD nucleation, GaN interface properties
4. Nucleation layer – transfer of bow from oxide, GaN parameters such as FWHM
5. Gate dielectric – in situ passivation, 2DEG performance

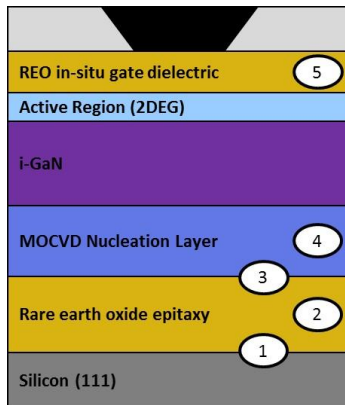

YD: When do you think the patent battle will start?

DW: Just one case has been made public, between IR and EPC. Nothing else seems to have started until now. The market is just starting at the moment, so it is too early for such patent case. We think that translucent is providing an original solution for the bow management of GaN on Si epiwafers and the patent portfolio of Translucent is here to support the company growth.

YD: What will be the next step of the industry according to you?

DW: Well, I think that we are about to see a consolidation of the involvement of the power electronic companies in GaN on Si. M&A will happen within 18 months so that the big companies get access to the GaN on Si technology when it will be ready for mass production. This day is approaching rapidly...

[Read more](#)

Azzurro Semiconductors went bankrupt... A hard blow for GaN-on-Si technology!

I-micronews

This old proverb from the semiconductor industry was also developed for GaN-based applications (LED, power electronics, RF and laser) too.

However, recently, such “rule” has shown its limit. Based upon data from the Dresdner Neuesten Nachrichten (www.dnn-online.de), it seems that the German GaN-on-Si epiwafer producer Azzurro Semiconductors went bankrupt. According to this source, “the company had not been able to bring its innovative technology to the market and make money”. As a result, the majority of the 42 people have been laid-off.

Azzurro Semiconductors had been spun off by renowned professors from the University of Magdeburg in 2003. These professors had invented a novel method to coat ordinary Silicon wafers, common in the chip industry, with Gallium Nitride (GaN). In the past years, Silicon substrate has created a lot of interest in the LED, RF and power electronics industry, with the final objective to decrease manufacturing cost by using depreciated CMOS fab.

But, after setting up its first factory in Dresden at a cost of around €19M and despite a new investor bailed out after months of negotiations, Azzurro Semiconductors applied to the bankruptcy court with insolvency proceedings that were opened on 30th of April (2014).

Step back in time, RF was the first application trying to capture the added-value of GaN-on Si technology for commercial products (Nitronex 1999). LED then joined the battlefield with Lattice Power then more recently Toshiba and Bridgelux, aiming to displace Sapphire domination. In power switching, pioneers were International Rectifier and EPC, followed by numerous new entrants since then, all targeting low cost, high power conversion efficiency devices.

As a conclusion, that very sad news shows how GaN-on-Si technology is still in its infancy, with winning business models (in-house or subtracted epi) not being fully stabilized yet. Market volumes

are not large enough to sustain massive up-stream investments at the moment and the question mark remains again: Will power and LED GaN-on-Si device makers process GaN epi internally or not.... Future will tell...

[Read more](#)

Gallium market to grow 40% by 2020 as general lighting rises from 18% to 33% of demand

Semiconductor Today

Demand for gallium will rise rapidly between 2014 and 2020 as general lighting moves away from incandescent and fluorescent lamps to light-emitting diodes, but this strong growth is unlikely to result in any tightness in supply as the market is oversupplied and likely to remain so, forecasts market research firm Roskill Information Services Ltd in the latest edition of its report 'Gallium: Global Industry Markets & Outlook'.

Production dominated by China

Chinese capacity for primary gallium production (as a by-product of alumina) is estimated to have risen from a third to 80% of the global total between 2009 and 2013. Despite the increase in capacity, world production of primary gallium is estimated by the United States Geological Survey (USGS) to have fallen by about 100 tons in 2013 to 280 tons. Some 220 tons of this was produced in China, where stocks are accumulating. Recycling, particularly in Japan, is an important element of supply.

Consumption mainly in Japan, but China is catching up

By far the largest market is in Japan, but its share of the global market is estimated to have fallen from as high as 80% in the mid-2000s to about 50% in 2013. While Japan is likely to remain the world's dominant gallium market for some years, the growth of the optoelectronics and electronics industries in China, together with the abundant domestic supply of gallium, indicates that the Chinese market will eventually become the largest. The global gallium market is forecast to rise by 40% to about 422 tons per year (tpy) by 2020, with use in general lighting rising from 18% to 33% of total demand. Gallium's use for electronic power management will remain the

largest market, but will decline from 50% to 43% of the total, forecasts the report.

Use of GaN expanding rapidly

The use of gallium nitride (GaN)-based integrated circuits and LEDs is widening and increasing, with a number of companies researching and developing its potential, notes the report. The use of gallium compound LEDs (particularly GaN-based) in all types of solid-state lighting (SSL) applications has become a major use for gallium. The SSL market comprises architectural, commercial, consumer portable (e.g. torches), industrial, outdoor and residential, signals (e.g. traffic lights) and motor vehicles. Architectural lighting has been the largest market, but may be overtaken by outdoor and residential lighting.

GaN power semiconductors can operate at higher temperatures, power levels, voltages and frequencies than gallium arsenide (GaAs) and silicon. There are power applications for GaN in power distribution, industrial and heavy electrical systems, and turbines, heavy machinery, advanced industrial control systems and electro-mechanical computing systems. GaN can also work across a very broad range of other high-frequency, high-power and microwave electronic devices used in cable TV, aerospace applications, utility grids, electric vehicles and wireless applications such as base-stations. GaN semiconductors are also used in LEDs for backlighting of LCD flat panel displays in computers, TVs and mobile telephones, and in signage, adds the report.

GaAs semiconductors and semi-insulators remain an important market

GaAs has historically been the most widely used gallium compound semiconductor. Its main modern uses are in power amplifiers - principally for mobile phone ICs - and in LEDs for backlighting of televisions, computers and phones.

Speed is the main advantage of GaAs. It is a faster, more efficient substrate material than silicon for ICs as electrons travel about five times faster in GaAs than they do in silicon. In addition, GaAs can operate over a wider range of temperatures than silicon, and has much higher radiation hardness. It is hence particularly useful for space applications and military hardware.

Thin-film PV cells potentially a growing market for gallium

A small amount of gallium is used in thin-film copper indium gallium (di)selenide (CIGS) photovoltaic (PV) cells. Thin-film technology is being researched intensively, because it is much lighter and more flexible than silicon crystal, and its use is growing. The semiconducting materials used to absorb the sun's rays are deployed as thin films only a few microns deep. Amorphous silicon, cadmium telluride (CdTe) and copper indium (di)selenide (CIS) compete with CIGS in the thin-film market, notes the report.

Impact of changes in gallium market on prices?

Despite growing demand for use in LED lighting, and a widely held expectation that GaN-based LED lighting will become the norm in the next ten years, gallium prices in 2013 and the early part of 2014 fell to their lowest ever levels in real terms. This is because gallium supplies from a combination of both primary and secondary sources are deemed more than sufficient to meet any likely demand. With only 11 producers of primary gallium in the world (seven of which are in China), it is possible that a producer price, based on costs and a profit margin, could come into force. This may lead to a gradual increase in prices from the very low levels seen in first-half 2014, reckons the report.

[Read more](#)

NALCO sourcing technology for 10 tonne per annum gallium extraction plant

Semiconductor Today

National Aluminium Company Ltd (NALCO, India's largest domestic aluminium producer) has invited expressions of interest (EoI) for sourcing an environmentally friendly technology for a 10 tonne per annum (TPA) gallium extraction plant that it plans to establish at its Alumina Refinery in Damanjodi, Odisha State, India either through a joint venture or standalone. The firm targets gallium metal with a purity of >99.99% (4N+).

[Read more](#)



23/05/2014

What do you think of the MACOM GaN Manifesto?



Patrick Hindle

Technical Editor at Microwave Journal covering the RF/microwave industry
 Contributor principal
 MACOM intends to mainstream the use of GaN on Si with the low cost structure of 8" Si fabrication and plastic packaging along with the lower cost of the Si versus SiC substrate.



Marcello Binetti

Product Line Manager at LayTec

Dear Patrick,

thanks for pointing out this publication: the Goal is lofty, but if they can really keep the production within the tight specifications they claim, they will get a big chunk of the market. One of the main issues I see is how to control the strain in the wafers to have both uniform deposition on the 8" wafer (at the growth temperature) and a flat Wafer during the process.

If they can tackle this issue, I think they will have good chances to produce on 8".



Armin Dadgar

Researcher / apl. Professor at Otto-von-Guericke-University Magdeburg and co-founder of AZZURRO Semiconductors AG

Hi Marcello,

flat wafers are the minor problem. As you know using in-situ curvature tools it is possible to

control the bow. But there are many other issues. When there is still Si processd in those Si fabs it is not yet known if there are any problems with Ga, Al, or In contaminations when processing GaN FETs. Fe doping is usually forbidden and C-doping of GaN often leads to lower material quality and performance. Another issue is reproducibility of the wafers. I do hear from many people that it is almost impossible to get identical wafers over a longer time period, even from the "best" Japanese company in this field. To me it seems FET wafers are still more difficult to produce than LED wafers where some percent brightness variation seem not to be a big issue while for FETs some more critical issues exist. That would explain the lack of good wafers I hear from everyone that wants to buy some. These problems might have also broken the neck of AZZURRO. There were not only wrong management decisions, but most likely also difficulties in FET growth, which seem to be bigger than expected.



Andrei Vescan

Professor at RWTH Aachen University

I wonder if "mainstream" will ever be the correct term for GaN technology. Is GaAs mainstream? Technical challenges are high, for power applications maybe higher than for RF. Still, it is exciting to see another serious player commit to this fantastic technology. I am eager to see them push GaN devices into the market.



Patrick Hindle

Technical Editor at Microwave Journal covering the RF/microwave industry
 Contributor principal

I consider GaAs a mainstream RF technology at this point. Anything that is in high rate

production (relatively speaking) for applications such as handset PA modules is considered mainstream in my book. Thanks for the comments.



William Stanchina

Professor at University of Pittsburgh

MACOM certainly presents a strong business rationale in announcing their plans based on their established expertise in compound semiconductors, the markets for compound semiconductor devices/ICs over the years, and their view of how the future application opportunities for GaN will bifurcate. I believe that GaN technology and the market needs this type of vision and courage; and I also believe that they (and IQE) will engineer the processes to be successful. I'll be excited to watch their progress and how others respond.



VICTOR GETMAN

Semiconductors Professional: Product, Device, Customer Quality, Implementation, Foundry, Project, R&D, Operations

It's not about 8" wafer size, it is about maintaining high yield to the spec. Also, MACOM's choice of old style leaded packages is questionable.



Andrei Vescan

Professor at RWTH Aachen University

Armin made an excellent point with respect to the general capability of growing GaN on Silicon reproducibly. The obviously inherent variability of this process has to be factored in when designing a device to specs and still achieve acceptable yield. There are some specs which are "hard", for example wafer bow. There is no

way we can design a viable process for 200µm wafer bow. However, many others may just need some reasonable amount of "overdesigning", which may be acceptable as long as cost is not significantly increased.

PATENT APPLICATION

More than **192 new patents** were published between 2014-04-20 and 2014-05-25.

Patent Applicants	Number of new patents
Xidian University	16
Sumitomo	12
Furukawa	8
University of California	6
Mitsubishi	6
Toshiba	5
Sharp	5
Advanced Optoelectronic Technology (AOT)	4
Avogy	4
Epilight Technology	4
Genesis Photonics	4
Inst. of Semiconductors - Chinese Academy of Sciences	4
LG	4
Panasonic	3
Fujitsu	3
Samsung	3
Hitachi	3
Power Integration, Tokuyama, Epistar, Element Six Technologies, Iljin, HC Semitek, Sora, Fuji Electric, RFMD, Nichia, CREE, Toyoda Gosei, Vishay Semiconductor, International Rectifier, IBM, Tongfang, Rohm, Jiangsu Xinguanglian Technology ...	

New patent applications selected by Knowmade

P type III-nitride materials and formation thereof

Publ. Nb: US8729561

Patent Assignee: International Rectifier (US)

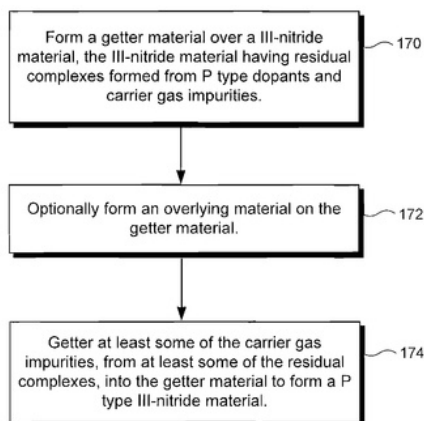

In one implementation, a method of forming a P type III-nitride material includes forming a getter material over a III-nitride material, the III-nitride material having residual complexes formed from P type dopants and carrier gas impurities. The method further includes gettering at least some of the carrier gas impurities, from at least some of the residual complexes, into the getter material to form the P type III-nitride material. In some implementations, the carrier gas impurities include hydrogen and the getter material includes at least partially titanium. An overlying material can be formed on the getter material prior to gettering at least some of the carrier gas impurities.

Gallium-Nitride-on-Diamond wafers and devices, and methods of manufacture

Publ. Nb: US2014141595

Patent Assignee: Element Six Technologies (US)

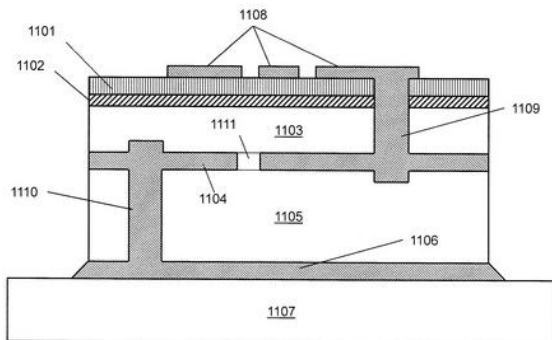

Methods for integrating wide-gap semiconductors, and specifically, gallium nitride epilayers with synthetic diamond substrates are disclosed. Diamond substrates are created by depositing synthetic diamond onto a nucleating layer deposited or formed on a layered structure that comprises at least one layer made out of gallium nitride. Methods for manufacturing GaN-on-diamond wafers with low bow and high crystalline quality are disclosed along with preferred choices for manufacturing GaN-on-diamond wafers and chips tailored to specific applications.

LED on silicon substrate using zinc-sulfide as buffer layer

Publ. Nb: US2014134765

Patent Assignee: Toshiba Techno Center (JP)

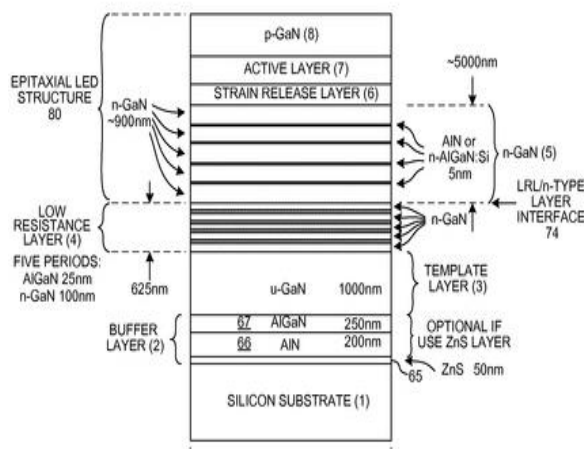

A vertical GaN-based blue LED has an n-type GaN layer that was grown over a ZnS layer that in turn was grown directly on a silicon substrate. In one example, the ZnS layer is a transitional buffer layer that is 50 nm thick, and the n-type GaN layer is at least 2000 nm thick. Growing the n-type GaN layer on the ZnS buffer layer reduces lattice defect density in the n-type layer. The ZnS buffer layer provides a good lattice constant match with the silicon substrate and provides a compound polar template for subsequent GaN growth. After the epitaxial layers of the LED are formed, a conductive carrier is wafer bonded to the structure. The silicon substrate and the ZnS buffer layer are then removed. Electrodes are added and the structure is singulated to form finished LED devices.

Semiconductor device, Schottky barrier diode, field-effect transistor, MIS type field-effect transistor, and MOS type field-effect transistor

Publ. Nb: JP2014086706

Patent Assignee: Furukawa Electric (JP), Next Generation Power Device Technology Research (JP)

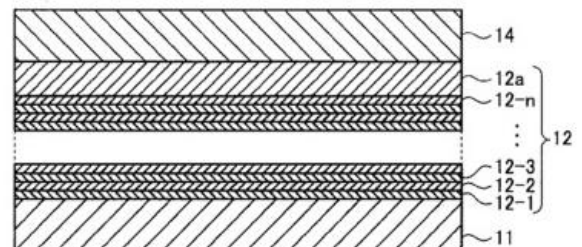

PROBLEM TO BE SOLVED: As 2 dimensional electron gas in electronic travelling layer high carrier density is maintained in high mobility, resisting pressure of the device improve. SOLUTION: Al_xGa_{1-x}N layer 12-1-12-n of the Al constitution x where 2 types differ to the higher stratum of society or the upper part of the electronic travelling layer 11 which consists of the un dope GaN layer which was formed on the specified base substance, at least (0<x<=1 and n: Natural number) electronic supply layer 12 of the superlattice which 4 layers or more is laminated is provided. As for each Al_xGa_{1-x}N layer 12-1-12-n, it forms in the film thickness which 2 dimensional electron gas does not

occur inside electronic supply layer 12. It is good laminating the field plate layer 14 which consists of AlzGa1-zN layer in higher stratum of society of electronic supply layer 12, in this case, the AlyGa1-yN layer 12a of first layer of electronic supply layer 12 as etching stop layer it designates. The lowest layer of electronic supply layer 12 as a AlN layer it is good.

Semiconductor device

Publ. Nb: JP2014086704

Patent Assignee: Next Generation Power Device Technology Research (JP)

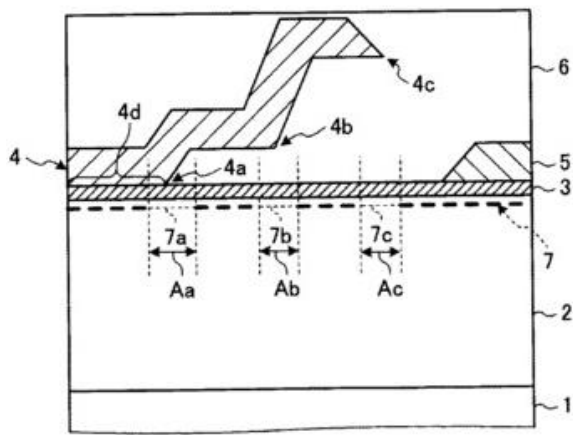

PROBLEM TO BE SOLVED: Offer the semiconductor device where decrease of resisting pressure is prevented.

SOLUTION: To be formed by the surface of 1st semiconductor layer and the aforementioned 1st semiconductor layer which consist of the nitride semiconductor which was formed on the baseplate being stranded to the aforementioned protecting film on the protecting film and the aforementioned 2nd semiconductor layer which consist of the insulator which was formed to the surface of 2nd semiconductor layer and the aforementioned 2nd semiconductor layer which consist of the nitride semiconductor where the van gap is wider than the aforementioned 1st semiconductor layer the 1st electrode which forms the stairway form which at least possesses the difference in level of 1 steps and the 2nd electrode which contacts the surface of the aforementioned 2nd semiconductor layer ohmic and, have, the aforementioned 1st semiconductor layerThe carrier occurs in the

boundary of the aforementioned 2nd semiconductor layer, carrier density of the said carrier the angular section of the difference in level of the aforementioned 1st electrode and at least either of the aforementioned 2nd electrode side end of the aforementioned 1st electrode at the 1st territory directly under one, the semiconductor device which is lower than the carrier density in the 2nd territory which is the other territory.

White light source employing a III-nitride based laser diode pumping a phosphor

Publ. Nb: WO2014074349

Patent Assignee: University Of California (US)

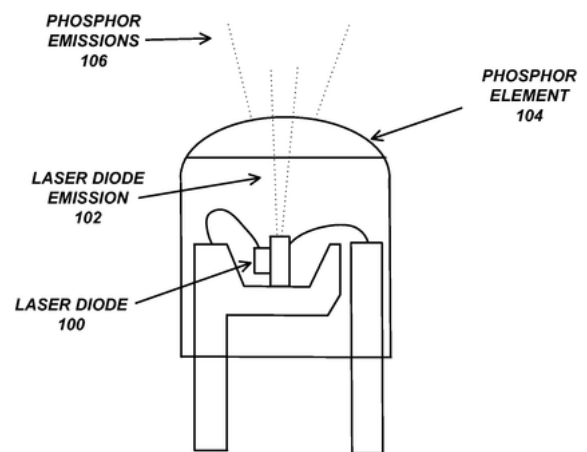

A white light source employing a III-nitride based laser diode pumping one or more phosphors. The III-nitride laser diode emits light in a first wavelength range that is down-converted to light in a second wavelength range by the phosphors, wherein the light in the first wavelength range is combined with the light in the second wavelength range to create highly directional white light. The light in the first wavelength range comprises ultraviolet, violet, blue and/or green light, while the light in the second wavelength range comprises green, yellow and/or red light.

Selective gallium nitride regrowth on (100) silicon

Publ. Nb: WO2014077941
 Patent Assignee: IBM (US)

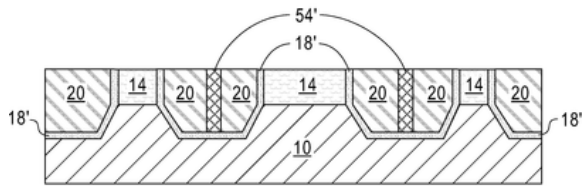

A method for selective formation of a gallium nitride material on a (100) silicon substrate. The method includes forming a blanket layer of dielectric material on a surface of a (100) silicon substrate. The blanket layer of dielectric material is then patterned forming a plurality of patterned dielectric material structures on silicon substrate. An etch is employed that selectively removes exposed portions of the silicon substrate. The etch forms openings within the silicon substrate that expose a surface of the silicon substrate having a (111) crystal plane. A contiguous AlN buffer layer is then formed on exposed surfaces of each patterned dielectric material structure and on exposed surfaces of the silicon substrate. A gallium nitride material is then formed on a portion of the contiguous AlN buffer layer and surrounding each sidewall of each patterned dielectric material structure.

Lateral GaN JFET with vertical drift region

Publ. Nb: WO2014078238
 Patent Assignee: Avogy (US)

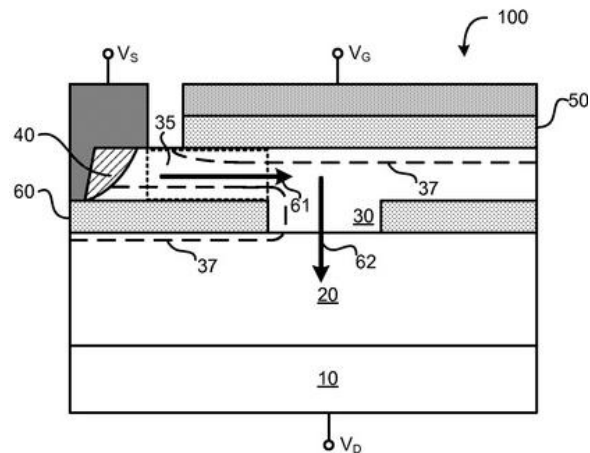

A gallium nitride (GaN)-based junction field-effect transistor (JFET) can include a GaN drain region having a top surface extending in a lateral dimension, a source region, and a GaN channel region of a first conductivity type coupled between the source region and the GaN drain region and operable to conduct electrical current between the source region and the GaN drain region. The JFET can also include a blocking layer disposed between the source region and the GaN drain region such that the GaN channel region is operable to conduct the electrical current substantially along the lateral dimension in a laterally-conductive region of the GaN channel region, and a GaN gate region of a second conductivity type coupled to the GaN channel region such that the laterally-conductive region of the GaN channel region is disposed between at least a portion of the blocking layer and the GaN gate region.

GaN High Voltage HFET with Passivation Plus Gate Dielectric Multilayer Structure

Publ. Nb: US2014124789
 Patent Assignee: Power Integrations (US)

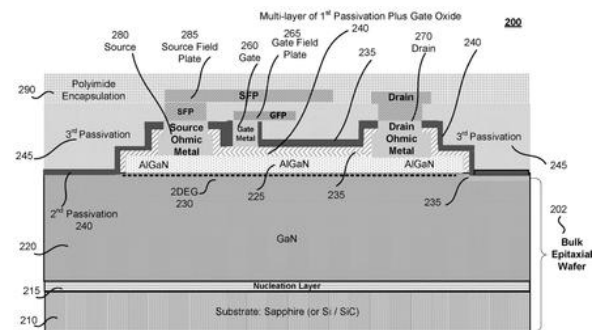

A method of fabricating a multi-layer structure for a power transistor device includes performing, within a reaction chamber, a nitrogen plasma strike, resulting in the formation of a nitride layer directly on a nitride-based active semiconductor layer. A top surface of the nitride layer is then exposed to a second source. A subsequent nitrogen-oxygen plasma strike results in the formation of an oxy-nitride layer directly on the nitride layer. The nitride layer comprises a passivation layer and the oxy-nitride layer comprises a gate dielectric of the power transistor device.

III-nitride quantum well structure, a method for producing the same, and a light-emitting unit using the same

Publ. Nb: US2014110664

Patent Assignee: National Sun Yat Sen University (TW)

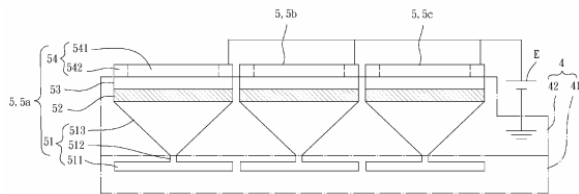

An III-nitride quantum well structure includes a GaN base, an InGaN layer and an InGaN covering layer. The GaN base includes a GaN buffering layer, a GaN post extending from the GaN buffering layer, and a GaN pyramid gradually expanding from the GaN post to form a mounting surface. The InGaN layer includes first and second coupling faces. The first coupling face is coupled with the mounting surface. The GaN covering layer includes first and second coupling faces. The first coupling face of the GaN covering layer is coupled with the second coupling face of the InGaN layer. A method for manufacturing the III-nitride quantum well structure and a light-emitting unit having a plurality of III-nitride quantum well structures are also proposed.



2405 route des Dolines, CS 10065
06902 Sophia Antipolis, France
contact@knowmade.fr
www.knowmade.com